

**CITY OF BROOK PARK
CUYAHOGA COUNTY, OHIO**

AUDIT REPORT

**FOR THE YEAR
ENDED DECEMBER 31, 2019**

James G. Zupka, CPA, Inc.
Certified Public Accountants



88 East Broad Street
Columbus, Ohio 43215
IPAReport@ohioauditor.gov
(800) 282-0370

Members of City Council
City of Brook Park
6161 Engle Road
Brook Park, Ohio 44142

We have reviewed the *Independent Auditor's Report* of the City of Brook Park, Cuyahoga County, prepared by James G. Zupka, CPA, Inc., for the audit period January 1, 2019 through December 31, 2019. Based upon this review, we have accepted these reports in lieu of the audit required by Section 117.11, Revised Code. The Auditor of State did not audit the accompanying financial statements and, accordingly, we are unable to express, and do not express an opinion on them.

Our review was made in reference to the applicable sections of legislative criteria, as reflected by the Ohio Constitution, and the Revised Code, policies, procedures and guidelines of the Auditor of State, regulations and grant requirements. The City of Brook Park is responsible for compliance with these laws and regulations.

Keith Faber
Auditor of State
Columbus, Ohio

July 15, 2020

This page intentionally left blank.

**CITY OF BROOK PARK
CUYAHOGA COUNTY, OHIO
AUDIT REPORT
FOR THE YEAR ENDED DECEMBER 31, 2019**

TABLE OF CONTENTS

	<u>PAGE</u>
Independent Auditor's Report	Under Separate Cover
Comprehensive Annual Financial Report	Under Separate Cover
Report on Internal Control Over Financial Reporting and on Compliance and Other Matters Based on an Audit of Financial Statements Required by <i>Government Auditing Standards</i>	1-2
Schedule of Prior Findings and Recommendations	3

This page intentionally left blank.

JAMES G. ZUPKA, C.P.A., INC.

Certified Public Accountants

5240 East 98th Street

Garfield Hts., Ohio 44125

Member American Institute of Certified Public Accountants

(216) 475 - 6136

Ohio Society of Certified Public Accountants

**REPORT ON INTERNAL CONTROL OVER FINANCIAL REPORTING
AND ON COMPLIANCE AND OTHER MATTERS REQUIRED BY
GOVERNMENT AUDITING STANDARDS**

To the Members of City Council
City of Brook Park
Brook Park, Ohio

The Honorable Keith Faber
Auditor of State
State of Ohio

We have audited, in accordance with the auditing standards generally accepted in the United States of America and the standards applicable to financial audits contained in Government Auditing Standards issued by the Comptroller General of the United States, the financial statements of the governmental activities, each major fund, and the aggregate remaining fund information of the City of Brook Park, Cuyahoga County, Ohio, (the City) as of and for the year ended December 31, 2019, and the related notes to the financial statements, which collectively comprise the City's basic financial statements, and have issued our report thereon dated June 23, 2020, wherein we noted the financial impact of COVID-19 and the ensuing emergency measures will impact subsequent periods of the City.

Internal Control Over Financial Reporting

In planning and performing our audit of the financial statements, we considered the City's internal control over financial reporting (internal control) to determine the audit procedures that are appropriate in the circumstances for the purpose of expressing our opinions on the financial statements, but not for the purpose of expressing an opinion on the effectiveness of the City's internal control. Accordingly, we do not express an opinion on the effectiveness of the City's internal control.

A deficiency in internal control exists when the design or operation of a control does not allow management or employees, in the normal course of performing their assigned functions, to prevent, or detect and correct, misstatements on a timely basis. A material weakness is a deficiency, or a combination of deficiencies, in internal control, such that there is a reasonable possibility that a material misstatement of the City's financial statements will not be prevented, or detected and corrected on a timely basis. A significant deficiency is a deficiency, or a combination of deficiencies, in internal control that is less severe than a material weakness, yet important enough to merit attention by those charged with governance.

Our consideration of internal control was for the limited purpose described in the first paragraph of this section and was not designed to identify all deficiencies in internal control that might be material weaknesses or significant deficiencies. Given these limitations, during our audit we did not identify any deficiencies in internal control that we consider to be material weaknesses. However, material weaknesses may exist that have not been identified.

Compliance and Other Matters

As part of obtaining reasonable assurance about whether the City's financial statements are free from material misstatement, we performed tests of its compliance with certain provisions of laws, regulations, contracts, and grant agreements, noncompliance with which could have a direct and material effect on the determination of financial statement amounts. However, providing an opinion on compliance with those provisions was not an objective of our audit, and accordingly, we do not express such an opinion. The results of our tests disclosed no instances of noncompliance or other matters that are required to be reported under *Government Auditing Standards*.

Purpose of This Report

The purpose of this report is solely to describe the scope of our testing of internal control and compliance and the results of that testing, and not to provide an opinion on the effectiveness of the City's internal control or on compliance. This report is an integral part of an audit performed in accordance with *Government Auditing Standards* in considering the City's internal control and compliance. Accordingly, this communication is not suitable for any other purpose.



James G. Zupka, CPA, Inc.
Certified Public Accountants

June 23, 2020

**CITY OF BROOK PARK
CUYAHOGA COUNTY, OHIO
SCHEDULE OF PRIOR AUDIT FINDINGS AND RECOMMENDATIONS
DECEMBER 31, 2019**

The prior audit report, as of December 31, 2018, included no findings or management letter recommendations.

This page intentionally left blank.



2019 ANNUAL REPORT

CITY OF BROOK PARK, OHIO
COMPREHENSIVE ANNUAL FINANCIAL REPORT
FOR THE YEAR ENDED DECEMBER 31, 2019

City of Brook Park, Ohio

**Comprehensive Annual Financial Report
For the Year Ended December 31, 2019**

**Issued by: Finance Department
Gregory M. Cingle, CPA, Finance Director
Martin S. Healy, Assistant Finance Director**

This page is intentionally left blank

INTRODUCTORY SECTION

City of Brook Park, Ohio
Comprehensive Annual Financial Report
For the Year Ended December 31, 2019
Table of Contents

Page

I. Introductory Section

Table of Contents	i
Letter of Transmittal	v
GFOA Certificate of Achievement	x
Organizational Chart-Departments	xi
City of Brook Park Elected Officials	xii

II. Financial Section

Independent Auditor’s Report.....	1
Management’s Discussion and Analysis.....	5
Basic Financial Statements:	
Government-wide Financial Statements:	
Statement of Net Position.....	17
Statement of Activities.....	18
Fund Financial Statements:	
Balance Sheet – Governmental Funds	19
Reconciliation of Total Governmental Fund Balances To Net Position of Governmental Activities.....	20
Statement of Revenues, Expenditures and Changes in Fund Balances – Governmental Funds.....	21
Reconciliation of the Statement of Revenues, Expenditures and Changes in Fund Balances of Governmental Funds to the Statement of Activities	22
Statement of Revenues, Expenditures and Changes in Fund Balance – Budget (Non-GAAP Budgetary Basis) and Actual:	
General Fund	23
Statement of Net Position – Proprietary Fund	24

City of Brook Park, Ohio
Comprehensive Annual Financial Report
For the Year Ended December 31, 2019
Table of Contents

Page

II. Financial Section (continued)

Statement of Revenues, Expenses and Changes in Net Position – Proprietary Fund	25
Statement of Cash Flows – Proprietary Fund	26
Statement of Fiduciary Net Position – Custodial Fund.....	27
Statement of Change in Fiduciary Net Position – Custodial Fund.....	28
Notes to the Basic Financial Statements.....	29
Required Supplementary Information:	
Schedule of the City’s Proportionate Share of the Net Pension Liability	88-89
Schedule of City Contributions – Net Pension Liability.....	90-91
Schedule of the City’s Proportionate Share of the Net OPEB Liability.....	92-93
Schedule of the City’s Net OPEB Liability	94-95
Schedule of City Contributions – OPEB.....	96-97
Notes to the Required Supplementary Information.....	98-99
Combining Statements and Individual Fund Schedules:	
Combining Statements: Non-Major Governmental Funds:	
Fund Descriptions	101
Combining Balance Sheet – Non-Major Governmental Funds.....	103
Combining Statement of Revenues, Expenditures and Changes in Fund Balances – Non-Major Governmental Funds	104
Combining Balance Sheet – Non-Major Special Revenue Funds.....	105
Combining Statement of Revenues, Expenditures and Changes in Fund Balances – Non-Major Special Revenue Funds	108

City of Brook Park, Ohio

Comprehensive Annual Financial Report For the Year Ended December 31, 2019

Table of Contents

Page

II. Financial Section (continued)

Individual Fund Schedules of Revenues, Expenditures and Changes in Fund

Balances – Budget (Non-GAAP Budgetary Basis) and Actual:

Major and Non-Major Funds:

General Fund.....	111
Capital Improvements Fund.....	120
Street Maintenance Fund.....	122
State Highway Fund.....	123
Permissive Tax Fund.....	124
Economic Development Fund.....	125
Brook Park Road Corridor Fund.....	126
CDBG Fund.....	127
Special Recreation Fund.....	128
Law Enforcement Fund.....	129
DWI Enforcement and Education Fund.....	130
Federal Forfeiture Fund.....	131
Community Diversion Fund.....	132
Retiree Accrued Benefits Fund.....	133
Continuing Training Program Fund.....	134
FEMA Fund.....	135
Police Pension Fund.....	136
Fire Pension Fund.....	137
Southwest General Health Center Fund.....	138
Cash Bonds Held Fund.....	139
General Obligation Fund.....	140
Self-Insured Medical Benefits.....	141

III. Statistical Section

Contents.....	S1
Net Position by Component – Last Ten Fiscal Years.....	S2
Changes in Net Position– Last Ten Fiscal Years.....	S3
Fund Balances, Governmental Funds – Last Ten Fiscal Years.....	S5
Changes in Fund Balances, Governmental Funds – Last Ten Fiscal Years.....	S6
Assessed Valuations and Estimated True Values – Last Ten Years.....	S8

City of Brook Park, Ohio

Comprehensive Annual Financial Report For the Year Ended December 31, 2019

Table of Contents

Page

III. Statistical Section (continued)

Property Tax Rates – Direct and Overlapping Governments – (Per \$1,000 of Assessed Valuation) – Last Ten Years	S9
Real Property Tax Levies and Collections – Last Ten Years	S10
Tangible Personal Property Tax Levies and Collections – Last Ten Years	S11
Principal Taxpayers – Real Estate Tax – 2019 and 2010.....	S12
Municipal Income Tax Revenues by Source – Last Ten Years	S13
Ratio of Outstanding Debt to Total Personal Income and Debt per Capita – Last Ten Years	S14
Ratio of Net General Bonded Debt to Assessed Value and Net Bonded Debt Per Capita – Last Ten Years.....	S15
Computation of Direct and Overlapping Debt.....	S16
Legal Debt Margin – Last Ten Fiscal Years	S17
Principal Employers – Current Year and 2010	S18
Demographic and Economic Statistics – Last Ten Years	S19
Full Time Employees by Function/Program – Last Ten Years	S20
Operating Indicators by Function/Program – Last Ten Years	S21
Capital Assets Statistics by Function/Program – Last Ten Years	S23

City of Brook Park

Finance Department

Gregory M. Cingle
Finance Director

Martin S. Healy
Assistant Finance Director

June 23, 2020

To the Honorable Mayor and Members of City Council,
And Citizens of Brook Park, Ohio:

State law requires that all general-purpose local governments publish within six months of the close of each fiscal year a complete set of financial statements presented in conformity with Generally Accepted Accounting Principles (GAAP) and audited in accordance with Generally Accepted Auditing Standards (GAAS) by a firm of licensed certified public accountants. Pursuant to that requirement, we hereby issue the Comprehensive Annual Financial Report (CAFR) of the city of Brook Park (City) for the fiscal year ended December 31, 2019.

This report consists of management's representations concerning the finances of the City. Consequently, management assumes full responsibility for the completeness and reliability of all of the information presented in this report. To provide a reasonable basis for making these representations, management of the City has established a comprehensive internal control framework that is designed to both compile sufficient reliable information for the preparation of the City's financial statements in conformity with GAAP and protect the government's assets from loss, theft or misuse. Since the cost of internal controls should not outweigh their benefits, the City's comprehensive framework of internal controls has been designed to provide reasonable rather than absolute assurance that the financial statements will be free from material misstatement. As management, we assure that, to the best of our knowledge and belief, this financial report is complete and reliable in all material respects.

The City's financial statements have been audited by James G. Zupka, C.P.A., Inc. The goal of the independent audit is to provide reasonable assurance that the financial statements of the City for the fiscal year ended December 31, 2019, are free of material misstatement. The independent audit involved examining, on a test basis, evidence supporting the amounts and disclosures in the financial statements, assessing the accounting principles used and significant estimates made by management and evaluating the overall financial statement presentation. The independent auditor concluded, based upon the audit, that there was a reasonable basis for rendering an unmodified opinion on the financial statements of the City for the fiscal year ended December 31, 2019, and that the financial statements are fairly presented in conformity with GAAP. The report of the independent auditor is presented as the first component of the financial section of this report.

The requirements of GAAP necessitate that management provide a narrative introduction, overview and analysis to accompany the basic financial statements in the form of Management's Discussion and Analysis (MD&A). This Letter of Transmittal is designed to complement the City's MD&A and should be read in conjunction with it. The MD&A can be found immediately following the report of the independent auditors.

Profile of the Government

The City, incorporated in 1967, is located in the Southwest portion of Cuyahoga County, 13 miles from Downtown Cleveland, with the cities of Parma to the east, Berea to the west and Middleburg Heights to the south. Brook Park is an easily accessible suburban community that abuts Cleveland Hopkins Airport on the Northwest boundary and has ready access to Interstates 71 and 480 and the Ohio Turnpike. With an excellent combination of residential, commercial and industrial areas that provide tax support, the City is able to finance the building of excellent administrative, recreational and service facilities as well as provide a wide variety of municipal services, such as police and fire services, street services, sewer services and recreation services.

The City operates under a mayor-council form of government. The mayor, designated by the charter as the chief executive officer of the City, is elected to serve a four-year term. The mayor has the power to appoint, promote, discipline, transfer, reduce or remove any employee of the City, except those elected, those who work for an elected official and those whose terms of office are set by the charter. Legislative authority is vested in an eight-member council. The council consists of a president, three council members elected at-large and four council members elected by ward. Council members are elected to serve a two-year term. Each member of council has a right to vote, except for the president, who may vote only in the event of a tie.

The mayor is entitled to a seat on council but has no voting rights. The mayor may veto any legislation passed by council. A veto may be overridden by a two-thirds vote of all members of council. The council fixes compensation of City officials and employees and enacts ordinances and resolutions relating to City services, tax levies, appropriations, indebtedness, the licensing of regulated businesses and trades and other municipal purposes.

Other elected officials include the finance director and law director, each of whom serve four-year terms.

Detailed provisions for the City's budget, tax levies and appropriations are set forth in the Ohio Revised Code and the charter. With the assistance of the finance director, the mayor is required to submit to council an estimate of the revenues and expenditures of the City for the succeeding fiscal year. The mayor submits to council an appropriation ordinance budget for the next succeeding fiscal year based on the annual estimate. Council is required to adopt said ordinance in its original form or with those revisions as it may find proper within 90 days of the beginning of the fiscal year.

The City maintains budgetary control on a non-GAAP basis by fund and within each fund by department at major object levels, which include personal services, travel and education, contractual services, supplies and materials, other expenditures, capital outlay, debt service and transfers. For management purposes, the major object level is further defined with budgeted amounts not to exceed the aggregate appropriated by council.

Budgetary control is maintained by an encumbrance of purchase commitment amounts prior to the release of purchase orders to vendors. Requisitions for the expenditure of monies are submitted to the mayor for approval and preparation of a purchase order. The purchase order is forwarded to the finance director's office for certification of the availability of funds. Once certified, the estimated expenditure is encumbered against the available appropriation. Unencumbered appropriations lapse at the end of each year. The City's accounting system provides interim financial reports that detail year-to-date expenditures plus encumbrances versus the original appropriations plus or minus any additional approved appropriations. The report permits the officials of the City to ascertain the status of a department's appropriations at any time during the year.

Factors Affecting Financial Condition

I. Economic Conditions and Outlook. In general, the U.S. economic growth continues at a moderate pace. Some of the factors are as follows:

- The 2019 calendar year realized job growth of over 2.1 million jobs.
- The Federal Reserve decreased the federal funds rate three times in 2019 from 2.25% to 1.50%.
- Many of the major market indexes realized their best performance since 2013.

II. Local Economic Activity. The City continues to work to sustain its existing economic base and also pursue new business opportunities.

- Work continues with the cities of Cleveland, Parma, Berea, North Olmsted, Middleburg Hts. And Olmsted Falls to create an Aerozone centered around Cleveland Hopkins Airport. The goal of the project is to enhance and generate new economic activity within designated areas of each of the communities.
- The City is working closely with Ford Motor Company with respect to approximately 195 acres of unused industrial land and several buildings located at Ford Motor Company's location in the City of Brook Park for redevelopment as an advanced technological or manufacturing center.
- The City applied for an Opportunity Zone designation (OZ) in the west-end area of the City near NASA Glenn. On March 27th, 2018, the City was informed that this area was designated as an OZ. This reinvestment zone was created as part of the new US income tax plan passed in December 2017, which allows for reinvestment of profits, which would be subject to capital gains, at a low or zero tax rate.
- Classic Auto Group will be building a new Nissan auto dealership to be located at 13445 Brookpark Rd. The location will employ approximately 50 individuals.
- The City is currently in discussions with the Glimcher Group, owners of Brook Gate Shopping Center, for the arrival of a new full service, family friendly restaurant. Estimated employment is 35 jobs.
- Corrigan Moving Systems will be building their ninth U.S. location on Keystone Parkway in order to service Northeast Ohio. Projected workforces is 45 employees.
- E.L. Mustee, a plumbing fixture manufacturer, is building a 46,753 square foot., \$2.2 million distribution facility on West 161st Street, which will create five new jobs.

III. Major Economic Initiatives. The City continued to focus on business retention, redevelopment opportunities, infrastructure improvements and prospecting for new business investment in the community.

Retention Activity:

- Ford Motor Company: Invested \$150 million in upgrades to its Cleveland Engine Plant in Brook Park. Engine Plant No. 1 continues production of Ford's 2.0-liter, 4 and 6-cylinder Eco-Boost engines.
- NASA Glenn ("Glenn"): The United States federal budget included \$400 million for programs and a new building at Glenn. The new \$47 million Aerospace Communications Facility will be located on the western side of the Center's 350-acre headquarters in Brook Park. The facility will consolidate existing work. The site will employ approximately 3,400 individuals.

IV. Redevelopment Planning.

- The City has received title to and is actively marketing a commercial property located on Brookpark Road.
- The City is working to attract and construct a \$3.5 million, 15,000 square ft. service, sales and parts truck center facility on Brookpark Road.
- The City continues to utilize the Master Plan that was finalized in 2012. The Master Plan assists in providing ideas for redevelopment, land use and zoning updates throughout the community.
- Brook Park currently owns 34 acres in the OZ that is available for purchase and development

Cash Management Policies and Practices

Cash management is a vital component of the City's overall financial strategy. Under the direction of the finance director, the City maintains an aggressive cash management program. Major considerations are timing of cash flows necessary to pay City liabilities and available interest rates. As City funds become available, they are invested immediately in short-term certificates of deposit or other securities authorized by state statutes. Interest earnings are allocated to funds based on the requirements of the Ohio Constitution and state statutes. All deposits and investments are covered by pooled collateral that has a face value equal to at least 102 percent of deposits.

Risk Management

The City has contracted with Wichert Insurance Company to negotiate property, general liability, boiler and machinery, automobile, law enforcement, public officials and umbrella insurance for the City. Medical insurance is provided for full-time employees and their families. The plan is fully-funded and administered by a third party administrator. The state of Ohio provides workers' compensation coverage for employees of the City.

Awards and Acknowledgements

Certificate of Achievement. The Government Finance Officers Association (GFOA) awarded a Certificate of Achievement for Excellence in Financial Reporting to the City for its CAFR for the fiscal year ended December 31, 2018. The Certificate of Achievement is a prestigious national award that recognizes conformance with the highest standards for preparation of state and local government financial reports.

In order to be awarded a Certificate of Achievement, the City published an easily readable and efficiently organized CAFR. This report conformed to program standards and satisfied both GAAP and applicable legal requirements.

The Certificate of Achievement is valid for a period of only one year. The City has received a Certificate of Achievement for the last 28 years. We believe that our current CAFR continues to meet the requirements for the Certificate of Achievement, and we are submitting it to the GFOA to determine its eligibility for another certificate.

Acknowledgement. The Finance Department, with the efficient and dedicated service of its entire staff, prepared this CAFR. We would like to express special appreciation to the independent accounting firm of James G. Zupka, CPA, Inc. for their assistance in preparing this report. In addition, we would like to thank the Mayor and each member of Brook Park City Council for their support, which has allowed the Finance Department to operate at the level that the residents of the City demand and deserve.

Respectfully submitted,



Gregory M. Cingle, CPA, MBA
Finance Director



Government Finance Officers Association

Certificate of
Achievement
for Excellence
in Financial
Reporting

Presented to

City of Brook Park
Ohio

For its Comprehensive Annual
Financial Report
for the Fiscal Year Ended

December 31, 2018

Christopher P. Morrill

Executive Director/CEO

City of Brook Park Administration

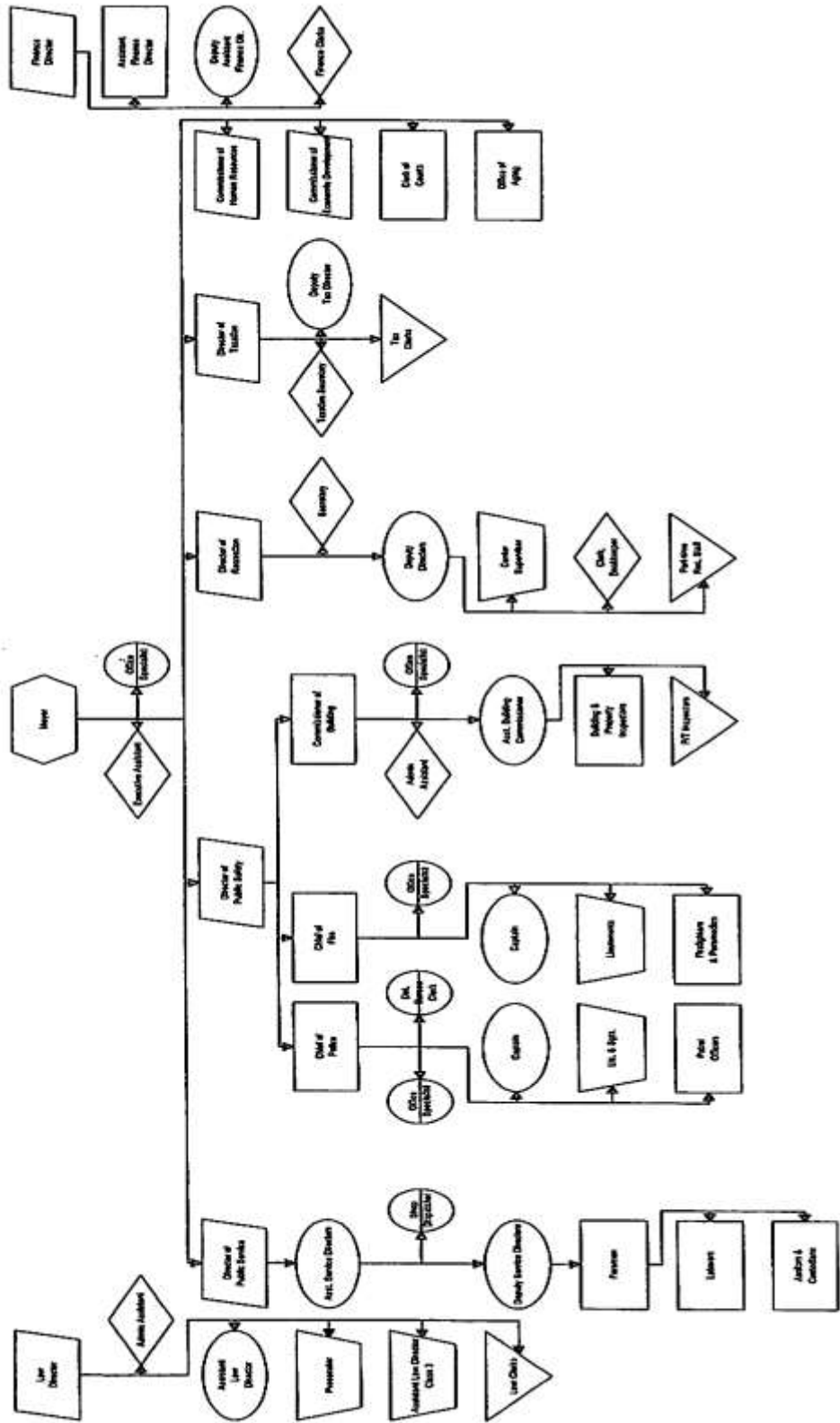

City of Brook Park, Ohio

Elected Officials

December 31, 2019

Mayor	Michael D. Gammella
Council Member – President	Mike Vecchio
Council Member – At-Large	Carl J. Burgio
Council Member – At-Large	Brian K. Poindexter
Council Member – At-Large	Richard A. Salvatore
Council Member – Ward 1	Gregory Stemm
Council Member – Ward 2	Jim Mencini
Council Member – Ward 3	Edward Orcutt
Council Member – Ward 4	Richard D. Scott
Finance Director	Gregory M. Cingle
Law Director	Carol Horvath

FINANCIAL SECTION

JAMES G. ZUPKA, C.P.A., INC.

Certified Public Accountants

5240 East 98th Street

Garfield Hts., Ohio 44125

Member American Institute of Certified Public Accountants

(216) 475 - 6136

Ohio Society of Certified Public Accountants

INDEPENDENT AUDITOR'S REPORT

To the Members of City Council
City of Brook Park
Brook Park, Ohio

The Honorable Keith Faber
Auditor of State
State of Ohio

Report on the Financial Statements

We have audited the accompanying financial statements of the governmental activities, each major fund, and the aggregate remaining fund information of the City of Brook Park, Cuyahoga County, Ohio, (the City) as of and for the year ended December 31, 2019, and the related notes to the financial statements, which collectively comprise the City's basic financial statements as listed in the table of contents.

Management's Responsibility for the Financial Statements

Management is responsible for the preparation and fair presentation of these financial statements in accordance with accounting principles generally accepted in the United States of America; this includes the design, implementation, and maintenance of internal control relevant to the preparation and fair presentation of financial statements that are free from material misstatement, whether due to fraud or error.

Auditor's Responsibility

Our responsibility is to express opinions on these financial statements based on our audit. We conducted our audit in accordance with auditing standards generally accepted in the United States of America and the standards applicable to financial audits contained in *Government Auditing Standards*, issued by the Comptroller General of the United States. Those standards require that we plan and perform the audit to obtain reasonable assurance about whether the financial statements are free from material misstatement.

An audit involves performing procedures to obtain audit evidence about the amounts and disclosures in the financial statements. The procedures selected depend on the auditor's judgment, including the assessment of the risks of material misstatement of the financial statements, whether due to fraud or error. In making those risk assessments, the auditor considers internal control relevant to the City's preparation and fair presentation of the financial statements in order to design audit procedures that are appropriate in the circumstances, but not for the purpose of expressing an opinion on the effectiveness of the City's internal control. Accordingly, we express no such opinion. An audit also includes evaluating the appropriateness of accounting policies used and the reasonableness of significant accounting estimates made by management, as well as evaluating the overall presentation of the financial statements.

We believe that the audit evidence we have obtained is sufficient and appropriate to provide a basis for our audit opinions.

Opinions

In our opinion, the financial statements referred to above present fairly, in all material respects, the respective financial position of the governmental activities, each major fund, and the aggregate remaining fund information of the City of Brook Park as of December 31, 2019, and the respective changes in financial position, and, where applicable, cash flows thereof and the budgetary comparison for the General Fund for the year then ended in accordance with accounting principles generally accepted in the United States of America.

Emphasis of Matter

As discussed in Note 20 to the basic financial statements, during 2019, the financial impact of COVID-19 and the ensuing emergency measures will impact subsequent periods of the City. Our opinion is not modified with respect to this matter.

Other Matters

Required Supplementary Information

Accounting principles generally accepted in the United States of America require that the Management's Discussion and Analysis and Schedules of Net Pension and Postemployment Benefit Liabilities and Pension and Postemployment Benefit Contributions, as listed in the table of contents, be presented to supplement the basic financial statements. Such information, although not a part of the basic financial statements, is required by the Governmental Accounting Standards Board, who considers it to be an essential part of financial reporting for placing the basic financial statements in an appropriate operational, economic, or historical context. We have applied certain limited procedures to the required supplementary information in accordance with auditing standards generally accepted in the United States of America, which consisted of inquiries of management about the methods of preparing the information and comparing the information for consistency with management's responses to our inquiries, the basic financial statements, and other knowledge we obtained during our audit of the basic financial statements. We do not express an opinion or provide any assurance on the information because the limited procedures do not provide us with sufficient evidence to express an opinion or provide any assurance.

Other Information

Our audit was conducted for the purpose of forming opinions on the financial statements that collectively comprise the City's basic financial statements. The introductory section, combining and individual nonmajor fund financial statements and schedules, and statistical section are presented for purposes of additional analysis and are not a required part of the basic financial statements.

The combining and individual nonmajor fund financial statements and schedules are the responsibility of management and were derived from and relate directly to the underlying

accounting and other records used to prepare the basic financial statements. Such information has been subjected to the auditing procedures applied in the audit of the basic financial statements and certain additional procedures, including comparing and reconciling such information directly to the underlying accounting and other records used to prepare the basic financial statements or to the basic financial statements themselves, and other additional procedures in accordance with auditing standards generally accepted in the United States of America. In our opinion, the combining and individual nonmajor fund financial statements and schedules are fairly stated in all material respects in relation to the basic financial statements as a whole.

The introductory and statistical sections have not been subjected to the auditing procedures applied in the audit of the basic financial statements and, accordingly, we do not express an opinion or provide any assurance on them.

Other Reporting Required by *Government Auditing Standards*

In accordance with *Government Auditing Standards*, we have also issued our report dated June 23, 2020, on our consideration of the City's internal control over financial reporting and on our tests of its compliance with certain provisions of laws, regulations, contracts, and grant agreements and other matters. The purpose of that report is to describe the scope of our testing of internal control over financial reporting and compliance and the results of that testing, and not to provide an opinion on internal control over financial reporting or on compliance. That report is an integral part of an audit performed in accordance with *Government Auditing Standards* in considering the City's internal control over financial reporting and compliance.



James G. Zupka, CPA, Inc.
Certified Public Accountants

June 23, 2020

This page is intentionally left blank.

City of Brook Park, Ohio

Management's Discussion and Analysis (Unaudited)

For the Year Ended December 31, 2019

The discussion and analysis of the City of Brook Park's (the City) financial performance provides an overall review of the City's financial activities for the year ended December 31, 2019. The intent of this discussion and analysis is to look at the City's financial performance as a whole. Readers are encouraged to consider this information in conjunction with the additional information contained in the financial statements and the notes thereof.

Financial Highlights

Key financial highlights for 2019 are:

- Revenue from municipal income and other taxes totaled \$21,231,634.
- Total assets and deferred outflows of resources increased by \$2,847,542 or a 2.40 percent increase from 2018. This increase was attributed mainly to deferred outflows of resources for pension which was offset by the decrease in capital assets, net due to the depreciation of capital assets
- Total net position increased by \$7,886,833 or a 15.73 percent increase from 2018.
- Total capital assets decreased by \$4,666,114 or a 5.54 percent decrease from 2018.
- Total liabilities and deferred inflows of resources decreased by \$5,039,291. This was a 7.36 percent decrease from 2018.
- At the end of the current fiscal year, the City's governmental funds reported combined ending fund balances of \$22,174,047 an increase of \$2,560,860 in comparison with the prior year's amount. Approximately 31.48 percent of this total amount, or \$6,980,856, is available for spending at the government's discretion (unassigned fund balance) without externally or internally imposed constraints.
- At the end of the current fiscal year, the General Fund's unassigned fund balance was \$6,980,856 or 35.17 percent of General Fund expenditures (not including other financing uses).

Using This Comprehensive Annual Financial Report (CAFR)

This annual report consists of a series of financial statements and notes to those statements. These statements are prepared and organized so the reader can understand the City both financially and operationally. The statements proceed to provide an increasingly detailed look at our specific financial condition.

The *Statement of Net Position* and *Statement of Activities* provide information about the activities of the whole City, presenting both an aggregate view of the City's finances and long-term view of those assets. Major fund financial statements provide the next level of detail. For governmental funds, these statements tell how services were financed in the short-term and what dollars remain for future spending. The fund financial statements also look at the City's most significant funds, with all other nonmajor funds presented in total in one column.

City of Brook Park, Ohio

Management's Discussion and Analysis (Unaudited) (continued)

For the Year Ended December 31, 2019

Reporting the City of Brook Park as a Whole

Statement of Net Position and Statement of Activities

While the CAFR contains information about the funds used by the City to provide services to our citizens, the *Statement of Net Position* and the *Statement of Activities* provide a view of the City's monetary transactions and answer the question, "How did the City do financially during 2019?" These statements include all assets, deferred outflows of resources, liabilities, and deferred inflows of resources using the accrual basis of accounting, which is similar to the accounting method used by the private sector. This accounting method takes into account all of the current year's revenues and expenses regardless of when cash is received or paid.

These two statements report the City's net position and the changes in net position. The changes in net position are important because it tells the reader whether the financial position of the City has improved or diminished. When evaluating the overall position of the City, non-financial information should also be considered, such as: changes in the City's tax base, amendments to property and income tax laws, condition of capital assets, etc.

The *Statement of Net Position* and the *Statement of Activities* will include the following governmental activities: police, fire, street maintenance, parks and recreation and general administration. Income taxes, property taxes and state and federal subsidy grants finance most of these activities.

The *Statement of Net Position* and the *Statement of Activities* are divided into the following categories:

- Assets
- Deferred Outflows of Resources
- Liabilities
- Deferred Inflows of Resources
- Net Position (Assets and Deferred Outflows of Resources minus Liabilities and Deferred Inflows of Resources)
- Program Revenues and Expenses
- General Revenues
- Net Position at the Beginning and End of Year

Reporting of the Most Significant Funds of the City of Brook Park

Fund Financial Statements

The presentation of the City's major funds begins on page 19. Fund financial statements provide detailed information about the City's major funds based on the restrictions on the use of monies. The City has established many funds to account for the multitude of services, facilities and infrastructure improvements provided to our residents. However, these fund financial statements focus on the City's most significant funds. In the case of the City, the major funds are the General and Capital Improvements Funds. All of the funds of the City can be divided into three categories: governmental funds, proprietary funds and fiduciary funds.

City of Brook Park, Ohio

Management's Discussion and Analysis (Unaudited) (continued)

For the Year Ended December 31, 2019

Governmental Funds

Governmental funds are used to account for essentially the same functions reported as governmental activities in the government-wide financial statements. However, unlike the government-wide financial statements, governmental fund financial statements focus on near-term inflows and outflows of spendable resources as well as on the balance of spendable resources available at the end of the fiscal year. Such information may be useful in evaluating the near-term financing requirements of a government. These funds are reported using an accounting method called modified accrual accounting, which measures cash and all other financial assets and deferred inflows of resources that can readily be converted to cash. The governmental fund statements provide a detailed short-term view of the City's general government operations and the basic services it provides. Both the *Governmental Funds Balance Sheet* and the *Governmental Funds Statement of Revenues, Expenditures and Changes in Fund Balances* provide a reconciliation to facilitate a comparison between governmental activities (reported in the *Statement of Net Position* and the *Statement of Activities*) and governmental funds.

The City maintains 21 individual governmental funds. Information is presented separately in the *Governmental Funds Balance Sheet* and in the *Governmental Funds Statement of Revenues, Expenditures and Changes in Fund Balances* for the General Fund and Capital Improvements Fund. Data from the other governmental funds are combined into single, aggregated presentations. Individual fund data for each of these nonmajor governmental funds is provided in this CAFR in the form of combining statements.

The City adopts an annual appropriated budget for each of its funds. A budgetary comparison statement (non-GAAP budgetary basis) has been provided for each governmental and proprietary fund to demonstrate budgetary compliance.

Proprietary Funds

Internal service funds are an accounting device used to accumulate and allocate costs internally among the various functions of a city. This fund has been included with governmental activities in the government-wide financial statements. The City maintains one proprietary fund for the self-insurance of health care benefits.

Proprietary funds provide the same type of information as the government-wide financial statements, only in more detail. The proprietary fund financial statements provide separate information for the Internal Service Fund. The basic proprietary fund financial statements can be found starting on page 24.

Fiduciary Funds

Fiduciary funds are used to account for resources held for the benefit of parties outside the government and are not reflected in the government-wide financial statements because resources are not available to support the City's own programs. The City has only one custodial fund to report within the fiduciary fund category.

Notes to the Financial Statements

The notes provide additional information that is essential for a full understanding of the data provided in the government-wide and fund financial statements. The notes to the financial statements can be found starting on page 29.

City of Brook Park, Ohio

Management's Discussion and Analysis (Unaudited) (continued)

For the Year Ended December 31, 2019

Other information

In addition to the basic financial statements and the accompanying notes, this CAFR also presents certain other information that the City believes readers will find useful. After the notes to the basic financial statements, the required supplementary information, notes to the required supplementary information, and the combining statements, referred to earlier in connection with nonmajor governmental funds, are presented along with individual detailed budgetary comparisons for all nonmajor funds. This information can be found starting on page 88.

The City as a Whole

The *Statement of Net Position* looks at the City as a whole and can prove to be a useful indicator of the City's financial position. Table 1 provides a summary of the City's net position for 2019 as compared to 2018.

Table 1
Net Position

	2019	2018
ASSETS		
Current and other assets	\$ 29,914,180	\$ 27,206,820
Net pension asset	21,497	25,948
Capital assets, net	79,495,330	84,161,444
Total Assets	<u>109,431,007</u>	<u>111,394,212</u>
DEFERRED OUTFLOWS OF RESOURCES		
Pension	9,616,096	4,675,570
OPEB	2,449,487	2,579,266
Total Deferred Outflows of Resources	<u>12,065,583</u>	<u>7,254,836</u>
LIABILITIES		
Current and other liabilities	944,062	812,812
Long-term liabilities:		
Due within one year	1,420,373	1,601,487
Due in more than one year		
Net Pension Liability	33,961,729	23,792,459
Net OPEB Liability	9,126,324	22,088,544
Other amounts	14,180,460	14,804,440
Total Liabilities	<u>59,632,948</u>	<u>63,099,742</u>
DEFERRED INFLOWS OF RESOURCES		
Property taxes	1,844,827	1,861,206
Pension	896,189	2,984,624
OPEB	1,088,835	556,518
Total Deferred Inflows of Resources	<u>3,829,851</u>	<u>5,402,348</u>
NET POSITION		
Net investment in capital assets	67,079,171	70,660,770
Restricted	4,535,580	8,818,517
Unrestricted	(13,580,960)	(29,332,329)
Total Net Position	<u>\$ 58,033,791</u>	<u>\$ 50,146,958</u>

* Restated

City of Brook Park, Ohio

Management's Discussion and Analysis (Unaudited) (continued)

For the Year Ended December 31, 2019

The net pension liability (NPL) is the largest single liability reported by the City at December 31, 2019 and is reported pursuant to GASB Statement 68, "Accounting and Financial Reporting for Pensions—an Amendment of GASB Statement 27." The City previously adopted GASB Statement 75, "Accounting and Financial Reporting for Postemployment Benefits Other Than Pensions," which significantly revises accounting for costs and liabilities related to other postemployment benefits (OPEB). For reasons discussed below, many end users of this financial statement will gain a clearer understanding of the City's actual financial condition by adding deferred inflows related to pension and OPEB, the net pension liability and the net OPEB liability to the reported net position and subtracting deferred outflows related to pension and OPEB and net pension asset.

Governmental Accounting Standards Board standards are national and apply to all government financial reports prepared in accordance with generally accepted accounting principles. Prior accounting for pensions (GASB 27) and postemployment benefits (GASB 45) focused on a funding approach. This approach limited pension and OPEB costs to contributions annually required by law, which may or may not be sufficient to fully fund each plan's net pension liability or net OPEB liability. GASB 68 and GASB 75 take an earnings approach to pension and OPEB accounting; however, the nature of Ohio's statewide pension/OPEB plans and state law governing those systems requires additional explanation in order to properly understand the information presented in these statements.

GASB 68 and GASB 75 require the net pension liability and the net OPEB liability to equal the City's proportionate share of each plan's collective:

1. Present value of estimated future pension/OPEB benefits attributable to active and inactive employees' past service.
2. Minus plan assets available to pay these benefits

GASB notes that pension and OPEB obligations, whether funded or unfunded, are part of the "employment exchange" – that is, the employee is trading his or her labor in exchange for wages, benefits, and the promise of a future pension and other postemployment benefits. GASB noted that the unfunded portion of this promise is a present obligation of the government, part of a bargained-for benefit to the employee, and should accordingly be reported by the government as a liability since they received the benefit of the exchange. However, the City is not responsible for certain key factors affecting the balance of these liabilities. In Ohio, the employee shares the obligation of funding pension benefits with the employer. Both employer and employee contribution rates are capped by State statute. A change in these caps requires action of both Houses of the General Assembly and approval of the Governor. Benefit provisions are also determined by State statute. The Ohio revised Code permits, but does not require the retirement systems to provide healthcare to eligible benefit recipients. The retirement systems may allocate a portion of the employer contributions to provide for these OPEB benefits.

The employee enters the employment exchange with the knowledge that the employer's promise is limited not by contract but by law. The employer enters the exchange also knowing that there is a specific, legal limit to its contribution to the retirement system. In Ohio, there is no legal means to enforce the unfunded liability of the pension/OPEB plan *as against the public employer*. State law operates to mitigate/lessen the moral obligation of the public employer to the employee, because all parties enter the employment exchange with notice as to the law. The retirement system is responsible for the administration of the pension and OPEB plans.

City of Brook Park, Ohio

Management's Discussion and Analysis (Unaudited) (continued)

For the Year Ended December 31, 2019

Most long-term liabilities have set repayment schedules or, in the case of compensated absences (i.e. sick and vacation leave), are satisfied through paid time-off or termination payments. There is no repayment schedule for the net pension liability or the net OPEB liability. As explained above, changes in benefits, contribution rates, and return on investments affect the balance of these liabilities, but are outside the control of the local government. In the event that contributions, investment returns, and other changes are insufficient to keep up with required payments, State statute does not assign/identify the responsible party for the unfunded portion. Due to the unique nature of how the net pension liability and the net OPEB liability are satisfied, these liabilities are separately identified within the long-term liability section of the statement of net position.

In accordance with GASB 68 and GASB 75, the City's statements prepared on an accrual basis of accounting include an annual pension expense and an annual OPEB expense for their proportionate share of each plan's change in net pension liability and net OPEB liability, respectively, not accounted for as deferred inflows/outflows.

Net position may serve over time as useful indicator of a government's financial position. The City's total assets and deferred outflows of resources exceeded its total liabilities and deferred inflows of resources at the close of 2019 by \$58,033,791. Due to the recording of GASB 68 and GASB 75, the City's unrestricted net position was a negative \$13,580,960.

The largest portion of the City's total net position reflects its net investment in capital assets, i.e. land, buildings, machinery, equipment, vehicles and infrastructure, less any related outstanding debt used to acquire those assets along with related deferred outflows/inflows of resources. The City uses these capital assets to provide services to citizens; consequently, these assets are not available for future spending. Although the City's investment in its capital assets is reported net of related debt and related deferred outflows/inflows of resources, it should be noted that resources needed to repay this debt must be provided from other sources since the capital assets themselves cannot be used to liquidate those liabilities and related deferred inflows of resources.

Total assets decreased by \$1,963,205 during the current year. This decrease was largely attributed to the depreciation of capital assets, which amounted to \$5,101,954, which was offset by the increase in current and other assets. Current and other assets increased due to an increase in equity and pooled cash and cash equivalents.

Total liabilities decreased by \$3,466,794, which is primarily due to the decrease in net OPEB liability, which was offset by the increase in net pension liability.

The changes in deferred outflows of resources and deferred inflows of resources are all due to the recording of GASB statements No. 68 and 75 as previously discussed.

The table presented on the following page is necessary to show the City's Net Position without the implementation of GASB 68 and GASB 75.

City of Brook Park, Ohio

Management's Discussion and Analysis (Unaudited) (continued)

For the Year Ended December 31, 2019

Table 2
Net Position without GASB 68 and GASB 75

Total Net Position including GASB 68 and GASB 75	\$	58,033,791
Add:		
Net Pension Liability		33,961,729
Net OPEB Liability		9,126,324
Deferred Inflows - Pension		896,189
Deferred Inflows - OPEB		1,088,835
Less:		
Deferred Outflows - Pension		9,616,096
Deferred Outflows - OPEB		2,449,487
Net Pension Asset		21,497
Total Net Position without GASB 68 and GASB 75	\$	<u>91,019,788</u>

Table 3 shows the changes in net position for 2019 as compared with 2018.

Table 3
Changes in Net Position

	<u>2019</u>	<u>2018</u>
REVENUES		
Program Revenues:		
Charges for services	\$ 3,683,260	\$ 3,659,589
Operating grants and contributions	1,382,622	986,429
Capital grants and contributions	1,445,346	171,590
Total Program Revenues	<u>6,511,228</u>	<u>4,817,608</u>
General Revenues:		
Property taxes	2,045,673	1,840,585
Municipal income and other taxes	21,231,634	19,911,095
Grants and entitlements	713,811	596,775
Investment income	204,679	188,782
All other revenues	154,380	33,583
Total General Revenues	<u>24,350,177</u>	<u>22,570,820</u>
Total Revenues	<u>30,861,405</u>	<u>27,388,428</u>
EXPENSES		
Program Expenses:		
Security of persons and property	1,595,353	13,944,020
General government	6,240,854	4,274,233
Public works	3,537,867	3,141,480
Leisure time activities	3,331,253	3,144,157
Transportation	6,004,889	4,656,162
Community development	1,639,970	1,264,341
Public health and welfare	258,849	148,650
Interest and fiscal charges	365,537	394,353
Total Expenses	<u>22,974,572</u>	<u>30,967,396</u>
Change in Net Position	7,886,833	(3,578,968)
Net Position - Beginning of Year	50,146,958	53,725,926
Net Position - End of Year	<u>\$ 58,033,791</u>	<u>\$ 50,146,958</u>

City of Brook Park, Ohio

Management's Discussion and Analysis (Unaudited) (continued)

For the Year Ended December 31, 2019

Governmental Activities

Several revenue sources fund the City's governmental activities, with City income tax being the largest contributor. The City's income tax rate is two percent on gross income and has not changed since 1991. Residents of the City who work in other communities and pay the withholding tax to those municipalities receive a 100 percent tax credit of up to two percent on their City income tax. During 2019, the revenues generated from municipal income tax and other miscellaneous taxes amounted to \$21,231,634. The 6.63 percent increase in income tax collections from 2018 to 2019 can mostly be attributed to withholding and net profit tax collections.

For 2019, City income tax revenue of 20 percent is earmarked for specific capital improvements. These revenues are allocated by City ordinance, providing that a substantial portion of the City's income tax collections be set aside for roads, city facilities and other capital requirements. Of the \$30,861,405 in total revenue, municipal income tax and other taxes accounted for 68.80 percent, property taxes accounted for 6.63 percent, charges for services accounted for 11.93 percent, and operating grants and contributions accounted for 4.48 percent of total revenue.

The combination of municipal income tax, property tax, charges for services, intergovernmental funding and operating and capital grants and contributions were not sufficient to fund all of the expenses in the governmental activities. The City monitors its sources of revenues very closely for fluctuations. There was an increase in capital grants and contributions in the amount of \$1,273,756, which is due to the contributions from the Ohio Department of Transportation and Ohio Public Works Commission for the Holland Road and Snow Road project in 2019.

The provisions of GASB Statements 68 and 75 require the City to recognize a pension/OPEB adjustment that reduces expenses by \$9,155,364 in 2019 (which causing the Security of Persons and Property – Fire expense on the statement of activates to be negative) and increased expenses by \$2,735,388 in 2018. As a result, it is difficult to ascertain the true operational cost of services and the changes in cost of service from year to year. The table below shows the total expenses by function with the GASB Statements 68 and 75 pension and OPEB expenses removed.

**Table 4
Expenses**

	<u>2019</u>	<u>2018</u>
EXPENSES		
Program Expenses:		
Security of persons and property	\$12,490,608	\$11,968,909
General government	5,477,168	3,946,934
Public works	3,198,354	3,044,109
Leisure time activities	3,102,341	3,026,867
Transportation	5,822,985	4,497,615
Community development	1,425,905	1,208,217
Public health and welfare	247,038	145,004
Interest and fiscal charges	365,537	394,353
Total Expenses	<u><u>\$32,129,936</u></u>	<u><u>\$28,232,008</u></u>

City of Brook Park, Ohio

Management's Discussion and Analysis (Unaudited) (continued)

For the Year Ended December 31, 2019

The largest program functions for the City relate to general government, transportation and public work. During 2019, general government accounted for 27.16 percent of program expenses, transportation accounted for 26.14 percent, and 15.40 percent of program expenses related to public work.

Program Expenses

For the year ended December 31, 2019, the City's total cost of services was \$32,129,936, with a net cost of services totaling \$25,618,708.

Table 5 itemizes fiscal year 2019 program expenses by specific function (excluding the pension and OPEB expenses as previously mentioned).

Table 5
Program Expenses

	Total Cost of Services 2019	Net Cost of Services 2019
Security of persons and property	\$ 12,490,608	\$ 11,346,524
General government	5,477,168	4,665,667
Public works	3,198,354	3,102,681
Transportation	3,102,341	610,770
Leisure time activities	5,822,985	5,493,947
Community development	1,425,905	(213,056)
Public health and welfare	247,038	246,638
Interest and fiscal charges	365,537	365,537
Total cost of service	<u>\$ 32,129,936</u>	<u>\$ 25,618,708</u>

The table above shows the total cost of services as well as the net cost of services. That is, it identifies the cost of the services supported by tax revenue and unrestricted intergovernmental revenues.

As referenced, most of the City's governmental activities rely on general revenues (property taxes, municipal income tax, grants, etc.) to support program expenses.

The City's Funds

Governmental Funds

The focus of the City's governmental funds is to provide information on near-term inflows, outflows and balances of spendable resources. Such information is useful in assessing the City's financing requirements. In particular, unassigned fund balances may serve as a useful measure of a government's net resources available for spending at the end of the year. Information about the City's governmental funds begins on page 19.

As of the end of the current fiscal year, the City's governmental funds reported combined ending fund balances of \$22,174,047. Of that amount, \$6,980,856 constitutes unassigned fund balances that are available for spending at the government's discretion without externally or internally imposed constraints. The remaining balance is nonspendable, restricted, committed, or assigned to indicate that it is not available for new spending.

City of Brook Park, Ohio

Management's Discussion and Analysis (Unaudited) (continued)

For the Year Ended December 31, 2019

General Fund

The General Fund is the chief operating fund of the City. As of December 31, 2019, the total fund balance for the General Fund was \$12,892,702, of which \$6,980,856 was unassigned. As a measure of the General Fund's liquidity, it may be useful to compare both unassigned fund balance and total fund balance to fund expenditures (not including other financing uses). Unassigned fund balance represents 35.17 percent of total General Fund expenditures, while total fund balance represents 64.95 percent of that same amount.

During 2019, the said fund balance increased by \$2,113,803 or 19.61 percent. This increase is due to revenues exceeding expenditures in 2019.

Capital Improvements Fund

The Capital Improvements Fund accounts for intergovernmental revenue in the form of grants as well as the portion of municipal income tax allocated by City Council for the purpose of improving, constructing, maintaining and purchasing those items necessary to enhance the operation of the City. As of December 31, 2019, the total fund balance for the Capital Improvements Fund was \$3,171,815, of which \$2,944,212 was committed due to constraints imposed by Council and \$227,603 was restricted by external constraints. The said fund balance decreased by \$666,870 during 2019. This decrease is mainly due to the Capital Improvement fund being stable enough to not rely as heavily on the General Fund transfers to support operations within the fund.

City Budget

The City's budget is prepared according to Ohio law and accounts for certain transactions on a basis of cash receipts, cash disbursements and encumbrances. The most significant budgeted fund is the General Fund. Except for agency funds, an annual appropriation budget is legally required to be prepared for all funds of the City. City Council is provided with a detailed line item budget for all departments.

After discussions at regularly held council meetings that are open to the public, the budget is adopted at the department level by object. Within each object, appropriations can be transferred between line items with the approval of the Finance Director and the respective department head. Council must approve any revisions in the budget that alter object level totals or total appropriations for any department or fund.

During the course of 2019, the City amended its General Fund budget once. The finance department watches all department expenditures closely to monitor compliance with allocated budgets and provides monthly reports to City Council that depicts monthly and year-to-date activity.

For the General Fund, the final budget basis revenue plus other financing sources was \$24,492,193 as compared to the original budget estimate plus other financing sources of \$22,636,074. The final budget, which is equal to the actual revenues excluding transfers, was higher than the original budget due to higher than expected income tax collections. The final appropriations plus other financing uses of \$25,196,847 were sufficient to meet the actual expenditures plus other financing uses for the year, which amounted to \$22,724,823. This is a result on of finance budgeting with conservatism.

City of Brook Park, Ohio

Management's Discussion and Analysis (Unaudited) (continued)

For the Year Ended December 31, 2019

Capital Assets and Debt Administration

Capital Assets

As of December 31, 2019, the City had \$79,495,330 invested in land, construction in progress, buildings and improvements, improvements other than buildings, machinery and equipment, furniture and fixtures, vehicles and infrastructure. Table 6 shows fiscal year 2019 balances of capital assets, net of depreciation, as compared to 2018.

Table 6
Capital Assets at Year End
(Net of Depreciation)

	<u>2019</u>	<u>2018</u>
Land	\$ 3,025,579	\$ 4,926,923
Construction in progress	1,984,009	5,495,383
Buildings and improvements	9,363,171	11,024,037
Improvements other than buildings	519,125	638,961
Machinery and equipment	1,070,003	1,151,099
Furniture and fixtures	16,205	21,225
Vehicles	2,999,268	3,366,203
Infrastructure:		
Streets	41,893,748	38,314,621
Sewers	17,342,185	17,907,860
Water Lines	1,282,037	1,315,132
Total Capital Assets	<u>\$ 79,495,330</u>	<u>\$ 84,161,444</u>

In 2019, the completion of various road projects and the Community Center Renovation resulted in a significant decrease in Construction in Progress in the amount of \$3,511,374. The \$4,666,114 decrease in total capital assets was a result of depreciation totaling \$5,101,954 for 2019.

With respect to infrastructure, the City engineer maintains a comprehensive listing of all the streets, bridges, culverts and sewer lines located within the City. As part of the annual road maintenance program, the City engineer evaluates the condition of each street after each winter and prepares a list of streets to be either resurfaced or crack sealed. In the case of concrete roads, the damaged portion will be either replaced or repaired. After approval from City Council, the projects are bid to get the best possible pricing from contractors. For additional information on capital assets, see Note 8 of the basic financial statements.

City of Brook Park, Ohio

Management's Discussion and Analysis (Unaudited) (continued)

For the Year Ended December 31, 2019

Debt

On December 31, 2019, the City had \$12,683,734 in outstanding debt, with \$808,580 of that debt due within one year. Table 7 below summarizes general obligation bonds, capital leases, and OPWC loans.

Table 7
Outstanding Debt at Year End

	<u>2019</u>	<u>2018</u>
General obligation bonds	\$ 9,755,000	\$ 10,325,000
Capital leases	540,565	1,022,130
OPWC loans	<u>2,388,169</u>	<u>2,457,310</u>
Total outstanding debt	<u>\$ 12,683,734</u>	<u>\$ 13,804,440</u>

As of December 31, 2019, the City's overall legal debt margin was \$37,463,484, with an unvoted debt margin of \$14,907,691.

More detailed information about the City's debt liabilities is presented in Note 9 of the basic financial statements.

Current Financial Related Activities

Local officials and Ford executives will continue to meet frequently to discuss current operating conditions and to strategize for new business alternatives that will keep the Brook Park Ford facility competitive in their corporate structure, resulting in a long-term existence within the City. In addition, discussions will continue on how to best develop the vacant acreage on the campus.

NASA Glenn, the largest taxpayer in the City, continues to be a tremendous asset to the community and region. City officials will continue to meet with Glenn administrators to discuss the current and future state of their facility.

In closing, local officials continue to work through the economic challenges facing the City and remain committed to providing full disclosure of the City's financial position to its residents.

Contacting the City's Finance Department

The CAFR is designed to provide our citizens, taxpayers, investors and creditors with a general overview of the City's finances and to show the City's accountability for the money it receives. If you have any questions about this CAFR or need additional financial information, please contact Finance Director Gregory M. Cingle, at the City of Brook Park, 6161 Engle Rd., Brook Park, Ohio, (216) 433-1300, or e-mail to info@cityofbrookpark.com.

City of Brook Park, Ohio
Statement of Net Position
December 31, 2019

	Governmental Activities
ASSETS	
Equity in Pooled Cash and Cash Equivalents	\$ 22,129,662
Cash and Cash Equivalents:	
In Segregated Accounts	39,482
Materials and Supplies Inventory	193,237
Accounts Receivable	212,333
Accrued Interest Receivable	12,533
Intergovernmental Receivable	1,511,319
Prepaid Items	408,510
Municipal Income Taxes Receivable	3,331,379
Property Taxes Receivable	1,921,429
Other Taxes Receivable	125,099
Special Assessments Receivable	29,197
Net Pension Asset	21,497
Nondepreciable Capital Assets	5,009,588
Depreciable Capital Assets	74,485,742
Total Assets	<u>109,431,007</u>
DEFERRED OUTFLOWS OF RESOURCES	
Pension	9,616,096
OPEB	2,449,487
Total Deferred Outflows of Resources	<u>12,065,583</u>
LIABILITIES	
Accounts Payable	182,789
Contracts Payable	98,573
Accrued Wages and Benefits	281,434
Intergovernmental Payable	57,158
Accrued Interest Payable	34,184
Retainage Payable	193,235
Unearned Revenue	96,689
Long-term Liabilities:	
Due within one year	1,420,373
Due in more than one year:	
Net Pension Liability (See Note 11)	33,961,729
Net OPEB Liability (See Note 12 & 13)	9,126,324
Other amounts	14,180,460
Total Liabilities	<u>59,632,948</u>
DEFERRED INFLOWS OF RESOURCES	
Property Taxes	1,844,827
Pension	896,189
OPEB	1,088,835
Total Deferred Inflows of Resources	<u>3,829,851</u>
NET POSITION	
Net Investment in Capital Assets	67,079,171
Restricted for:	
Debt Services	1,337,446
Capital Projects	227,603
Street Paving and Repair	2,404,362
Public Safety	360,212
Other Purposes	205,957
Unrestricted	(13,580,960)
Total Net Position	<u>\$ 58,033,791</u>

The notes to the basic financial statements are an integral part of this statement

City of Brook Park, Ohio
Statement of Activities
For the Year Ended December 31, 2019

	Expenses	Program Revenues		Capital Grants and Contributions	Net (Expense) Revenue and Changes in Net Position
		Charges for Services	Operating Grants and Contributions		
Governmental activities:					
Security of Persons and Property					
Police and Others	\$ 2,058,764	\$ 618,513	\$ 17,895	\$ -	\$ (1,422,356)
Fire	(463,411)	507,676	-	-	971,087
Public Health and Welfare	258,849	400	-	-	(258,449)
Leisure Time Activities	3,331,253	321,216	7,822	-	(3,002,215)
Community Development	1,639,970	1,421,074	217,887	-	(1,009)
Public Works	3,537,867	2,880	-	92,793	(3,442,194)
Transportation	6,004,889	-	1,139,018	1,352,553	(3,513,318)
General Government	6,240,854	811,501	-	-	(5,429,353)
Interest and Fiscal Charges	365,537	-	-	-	(365,537)
Total Governmental activities	\$ 22,974,572	\$ 3,683,260	\$ 1,382,622	\$ 1,445,346	(16,463,344)

General Revenues:

Property Taxes levied for:	
General Purposes	1,704,368
Other Purposes	341,305
Municipal Income Taxes levied for:	
General Purposes	17,713,859
Capital Outlay	3,099,154
Other Taxes	418,621
Grants & Entitlements not restricted to specific programs	713,811
Investment Income	204,679
All Other Revenues	154,380
Total General Revenues	<u>24,350,177</u>
Change in Net Position	7,886,833
Net Position - Beginning of Year	<u>50,146,958</u>
Net Position - End of Year	<u>\$ 58,033,791</u>

The notes to the basic financial statements are an integral part of this statement

City of Brook Park, Ohio
Balance Sheet – Governmental Funds
December 31, 2019

	<u>General Fund</u>	<u>Capital Improvements Fund</u>	<u>Other Governmental Funds</u>	<u>Total Governmental Funds</u>
ASSETS				
Equity in Pooled Cash and Cash Equivalents	\$ 10,728,870	\$ 3,008,398	\$ 5,442,796	\$ 19,180,064
Cash and Cash Equivalents:				
In Segregated Accounts	39,482	-	-	39,482
Materials and Supplies Inventory	193,237	-	-	193,237
Accrued Interest Receivable	9,240	-	3,293	12,533
Accounts Receivable	212,333	-	-	212,333
Intergovernmental Receivable	290,628	52,765	1,167,926	1,511,319
Prepaid Items	408,510	-	-	408,510
Municipal Income Tax Receivable	2,665,103	666,276	-	3,331,379
Property Taxes Receivable	1,575,940	-	345,489	1,921,429
Special Assessments Receivable	-	-	29,197	29,197
Other Taxes Receivable	125,099	-	-	125,099
Total Assets	<u>16,248,442</u>	<u>3,727,439</u>	<u>6,988,701</u>	<u>26,964,582</u>
LIABILITIES, DEFERRED INFLOWS OF RESOURCES AND FUND BALANCES				
Liabilities:				
Accounts Payable	\$ 157,052	\$ 1,751	\$ 23,986	\$ 182,789
Accrued Wages and Benefits	271,267	1,045	9,122	281,434
Contracts Payable	-	98,573	-	98,573
Intergovernmental Payable	21,564	147	35,447	57,158
Retainage Payable	-	193,235	-	193,235
Unearned Revenue	-	-	96,689	96,689
Total Liabilities	<u>449,883</u>	<u>294,751</u>	<u>165,244</u>	<u>909,878</u>
Deferred Inflows of Resources:				
Property Taxes	1,513,130	-	331,697	1,844,827
Unavailable Revenue - Delinquent Property Taxes	62,810	-	13,792	76,602
Unavailable Revenue - Income Taxes	1,043,493	260,873	-	1,304,366
Unavailable Revenue - Other	286,424	-	368,438	654,862
Total Deferred Inflows of Resources	<u>2,905,857</u>	<u>260,873</u>	<u>713,927</u>	<u>3,880,657</u>
Fund Balances:				
Nonspendable	601,747	-	-	601,747
Restricted	-	227,603	3,279,474	3,507,077
Committed	2,991,010	2,944,212	1,520,120	7,455,342
Assigned	2,319,089	-	1,309,936	3,629,025
Unassigned	6,980,856	-	-	6,980,856
Total Fund Balances	<u>12,892,702</u>	<u>3,171,815</u>	<u>6,109,530</u>	<u>22,174,047</u>
Total Liabilities, Deferred Inflows of Resources and Fund Balances	<u>\$ 16,248,442</u>	<u>\$ 3,727,439</u>	<u>\$ 6,988,701</u>	<u>\$ 26,964,582</u>

The notes to the basic financial statements are an integral part of this statement

City of Brook Park, Ohio

Reconciliation of Total Governmental Funds Balances to Net Position of Governmental Activities December 31, 2019

Total Governmental Funds Balance \$ 22,174,047

Amounts reported for Governmental Activities in the Statement of Net Position are different because:

Capital Assets used in Governmental Activities are not financial resources and, therefore, are not reported in the funds 79,495,330

Other long-term assets are not available to pay for current-period expenditures and, therefore, are unavailable revenues in the funds:

Delinquent property taxes	\$ 76,602	
Municipal income and other taxes	1,304,366	
Special assessments	29,197	
Intergovernmental	562,249	
Charges for services	<u>63,416</u>	
Total		2,035,830

In the Statement of Activities, interest is accrued on outstanding bonds, whereas in Governmental funds, an interest expenditure is reported when due. (34,184)

Internal Service funds are used by management to charge the costs of certain activities, such as insurance to individual funds. The assets of the Internal Service funds are included in Governmental Activities in the Statement of Net Position. 2,949,598

The net pension liability/asset and net OPEB Liability are not due and payable in the current period; therefore, the liability/asset and related deferred inflows/outflows are not reported in governmental funds:

Deferred Outflows - Pension	9,616,096	
Deferred Inflows - Pension	(896,189)	
Net Pension Liability/Asset	(33,940,232)	
Deferred Outflows - OPEB	2,449,487	
Deferred Inflows - OPEB	(1,088,835)	
Net OPEB Liability	<u>(9,126,324)</u>	
Total		(32,985,997)

Long-term liabilities, including bonds payable, are not due and payable in the current period and therefore are not reported in the funds:

General obligation bonds	(9,755,000)	
OPWC loans	(2,388,169)	
Unamortized bond premiums	(365,959)	
Capital leases	(540,565)	
Accrued compensated absences	<u>(2,551,140)</u>	
Total		<u>(15,600,833)</u>

Net Position of Governmental Activities \$ 58,033,791

The notes to the basic financial statements are an integral part of this statement

City of Brook Park, Ohio

Statement of Revenues, Expenditures and Changes in Fund Balances Governmental Funds For the Year Ended December 31, 2019

	General Fund	Capital Improvements Fund	Other Governmental Funds	Total Governmental Funds
REVENUES				
Property Taxes	\$ 1,703,197	\$ -	\$ 341,644	\$ 2,044,841
Municipal Income Taxes	17,501,715	3,046,118	-	20,547,833
Other Taxes	418,621	-	-	418,621
Intergovernmental	675,517	1,416,904	1,487,924	3,580,345
Interest	162,760	-	41,919	204,679
Licenses and Permits	699,072	-	70,245	769,317
Fines and Forfeitures	638,774	24,684	2,766	666,224
Rentals	50,165	-	-	50,165
Charges for Services	2,101,198	2,880	119,816	2,223,894
Contributions and Donations	3,547	-	2,822	6,369
Special Assessments	-	-	77,808	77,808
All Other Revenues	125,912	24,922	-	150,834
Total Revenues	24,080,478	4,515,508	2,144,944	30,740,930
EXPENDITURES				
Security of Persons and Property:				
Police and Others	6,146,356	-	696,547	6,842,903
Fire	4,183,036	-	781,747	4,964,783
Public Health and Welfare	134,349	-	111,522	245,871
Leisure Time Activities	1,218,962	-	106,483	1,325,445
Community Development	899,991	2,162	447,504	1,349,657
Public Works	2,082,317	-	-	2,082,317
Transportation	1,513,724	8,513	587,137	2,109,374
General Government	3,670,840	128,947	4,519	3,804,306
Capital Outlay	-	4,482,252	-	4,482,252
Debt Service:				
Principal Retirement	-	481,565	745,830	1,227,395
Interest and Fiscal Charges	-	22,814	376,900	399,714
Total Expenditures	19,849,575	5,126,253	3,858,189	28,834,017
Excess of Revenues (Under) Expenditures	4,230,903	(610,745)	(1,713,245)	1,906,913
OTHER FINANCING SOURCES (USES)				
Sale of Capital Assets	-	18,219	529,039	547,258
OPWC Loans Issued	-	106,689	-	106,689
Transfers In	563,588	1,050,000	2,410,735	4,024,323
Transfers Out	(2,680,688)	(1,231,033)	(112,602)	(4,024,323)
Total Other Financing Sources (Uses)	(2,117,100)	(56,125)	2,827,172	653,947
Net Change in Fund Balances	2,113,803	(666,870)	1,113,927	2,560,860
Fund Balances - Beginning of Year	10,778,899	3,838,685	4,995,603	19,613,187
Fund Balances - End of Year	\$ 12,892,702	\$ 3,171,815	\$ 6,109,530	\$ 22,174,047

The notes to the basic financial statements are an integral part of this statement

City of Brook Park, Ohio

Reconciliation of the Statement of Revenues, Expenditures and Changes in Fund Balances of Governmental Funds to the Statement of Activities For the Year Ended December 31, 2019

Net Change in Fund Balances-Total Governmental Funds \$ 2,560,860

Amounts reported for Governmental Activities in the Statement of Activities are different because:

Governmental funds report capital outlays as expenditures. However, in the Statement of Activities, the cost of those assets is allocated over their estimated useful lives as depreciation expense. This is the amount by which depreciation exceeded capital outlays in the current period.

Capital Outlay	\$	2,347,851	
Depreciation		(5,101,954)	
Total			(2,754,103)

In the Statement of Activities, only the loss on the disposal of capital assets is reported, whereas, in the Governmental Funds, the proceeds from the disposals increase financial resources. Thus, the change in net position differs from the change in fund balance by the net book value of the capital assets. (1,912,011)

Revenues in the Statement of Activities that do not provide current financial resources are not reported as revenues in the funds.

Delinquent property taxes		832	
Municipal income taxes		265,180	
Special assessments		(49,750)	
Intergovernmental		(147,066)	
Charges for services		63,416	
Total			132,612

Repayment of bond, lease, and loan principal are expenditures in the Governmental funds, but the repayment reduces long-term liabilities in the Statement of Net Position. 1,227,395

Contractually required contributions are reported as expenditures in governmental funds; however, the statement of net position reports these amounts as deferred outflows.

Pension			2,152,736
OPEB			125,905

Except for amounts reported as deferred inflows/outflows, changes in the net pension/OPEB liability are reported as pension expense in the statement of activities.

Pension			(5,297,496)
OPEB			12,174,219

The issuance of long-term debt provides current financial resources to governmental funds, but has no effect on net position (106,689)

Some expenses reported in the Statement of Activities do not require the use of current financial resources and therefore are not reported as expenditures in Governmental funds.

Accrued compensated absences		(342,764)	
Accrued interest on bonds		7,025	
Amortization of bond premiums		27,152	
Total			(308,587)

Internal Service funds are used by management to charge costs to certain activities, such as insurance to individual funds. The net revenue (expense) of Internal Service funds are reported in the Governmental Activities. (108,008)

Change in Net Position of Governmental Activities \$ 7,886,833

The notes to the basic financial statements are an integral part of this statement

City of Brook Park, Ohio

Statement of Revenues, Expenditures and Changes in Fund Balances – Budget (Non-GAAP Budgetary Basis) and Actual

General Fund

For the Year Ended December 31, 2019

	Budgeted Amounts		Actual	Variance with Final Budget Positive (Negative)
	Original	Final		
Revenues:				
Property Taxes	\$ 1,612,669	\$ 1,703,197	\$ 1,703,197	\$ -
Municipal Income Taxes	16,673,226	17,366,035	17,366,035	-
Other Taxes	354,300	344,814	344,814	-
Intergovernmental	582,409	671,685	671,685	-
Interest	175,875	168,140	168,140	-
Licenses and Permits	598,106	697,990	697,990	-
Fines and Forfeitures	515,000	625,041	625,041	-
Rentals	50,165	50,165	50,165	-
Charges for Services	1,866,257	2,225,387	2,225,387	-
Contributions and Donations	3,547	3,547	3,547	-
All Other Revenues	51,918	42,604	42,604	-
Total Revenues	22,483,472	23,898,605	23,898,605	-
Expenditures:				
Current:				
Security of Persons and Property	11,056,620	11,268,437	10,381,490	886,947
Public Health and Welfare	131,919	135,882	134,179	1,703
Leisure Time Activities	1,284,450	1,295,962	1,226,739	69,223
Community Development	908,997	913,561	865,261	48,300
Public Works	2,386,660	2,408,160	2,266,517	141,643
Transportation	729,709	730,709	539,540	191,169
General Government	5,440,294	5,432,946	4,299,907	1,133,039
Total Expenditures	21,938,649	22,185,657	19,713,633	2,472,024
Excess of Revenues Over (Under) Expenditures	544,823	1,712,948	4,184,972	2,472,024
Other Financing Sources (Uses)				
Transfer In	152,602	593,588	593,588	-
Transfers Out	(2,220,689)	(3,011,190)	(3,011,190)	-
Total Other Financing Sources (Uses)	(2,068,087)	(2,417,602)	(2,417,602)	-
Net Change in Fund Balance	(1,523,264)	(704,654)	1,767,370	2,472,024
Cash Fund Balance - Beginning of Year	8,631,553	8,631,553	8,631,553	-
Current Year Encumbrances	-	-	197,320	197,320
Cash Fund Balance - End of Year	\$ 7,108,289	\$ 7,926,899	\$ 10,596,243	\$ 2,669,344

See accompanying notes to the basic financial statements.

City of Brook Park, Ohio
Statement of Net Position
Proprietary Fund
December 31, 2019

	<u>Governmental Activities Internal Service Fund</u>
ASSETS	
Current Assets:	
Equity in Pooled Cash and Cash Equivalents	\$ 2,949,598
Total Assets	<u>2,949,598</u>
NET POSITION	
Unrestricted	2,949,598
Total Net Position	<u>\$ 2,949,598</u>

The notes to the basic financial statements are an integral part of this statement

City of Brook Park, Ohio

Statement of Revenues, Expenses and Changes in Net Position

Proprietary Fund

For The Year Ended December 31, 2019

	Governmental Activities
	Internal Service Fund
OPERATING EXPENSES	
Fringe Benefits	\$ 108,008
Total Operating Expense	<u>108,008</u>
Change in Net Position	(108,008)
Net Position - Beginning of Year	<u>3,057,606</u>
Net Position- End of Year	<u><u>\$ 2,949,598</u></u>

The notes to the basic financial statements are an integral part of this statement

City of Brook Park, Ohio
Statement of Cash Flows
Proprietary Fund
For The Year Ended December 31, 2019

	<u>Governmental Activities Internal Service Fund</u>
CASH FLOWS FROM OPERATING ACTIVITIES	
Cash Payments for Claims	\$ (108,008)
Net Cash Used In Operating Activities	<u>(108,008)</u>
Net decrease in Cash and Cash Equivalents	(108,008)
Cash and Cash Equivalents - Beginning of Year	<u>3,057,606</u>
Cash and Cash Equivalents - End of Year	<u><u>\$ 2,949,598</u></u>
RECONCILIATION OF OPERATING LOSS TO NET CASH PROVIDED BY OPERATING ACTIVITIES	
Operating Loss	\$ (108,008)
Net Cash Used In Operating Activities	<u><u>\$ (108,008)</u></u>

The notes to the basic financial statements are an integral part of this statement

City of Brook Park, Ohio
Statement of Fiduciary Net Position
Custodial Fund
December 31, 2019

	<u>Custodial Fund</u>
ASSETS	
Equity in Pooled Cash and Cash Equivalents	<u>\$ 8,670</u>
Total Assets	<u><u>8,670</u></u>
LIABILITIES	
Intergovernmental Payable	<u>8,670</u>
Total Liabilities	<u><u>\$ 8,670</u></u>

See accompany notes to the basic financial statements.

The notes to the basic financial statements are an integral part of this statement

City of Brook Park, Ohio
Statement of Changes in Fiduciary Net Position
Custodial Fund
For the Year Ended December 31, 2019

	Custodial Fund
ADDITIONS	
Licenses, Permits, & Fees Distributions for Other Governments	\$ 4,251
Total Additions	<u>4,251</u>
DEDUCTIONS	
Distributions to the State of Ohio	<u>4,251</u>
Total Deductions	<u>4,251</u>
Net Increase (Decrease) in Fiduciary Net Position	-
Net Position - Beginning of Year	<u>-</u>
Net Position - End of Year	<u><u>\$ -</u></u>

See accompany notes to the basic financial statements.

The notes to the basic financial statements are an integral part of this statement

City of Brook Park, Ohio

Notes to the Basic Financial Statements

For The Year Ended December 31, 2019

Note 1: The Reporting Entity

The City of Brook Park (the City) is a home rule municipal corporation established under the laws of the State of Ohio which operates under its own Charter. The current Charter, which provides for a mayor-council form of government, was adopted October 18, 1966.

A reporting entity is comprised of the primary government, component units and other organizations that are included to ensure that the financial statements are not misleading. The primary government of the City consists of all funds, departments, boards and agencies that are not legally separate from the City. For the City, this includes police and fire protection, parks and recreation, planning, zoning, street maintenance and repair, refuse collection and general administrative services. The City's departments include a public safety department, a public service department, a street maintenance department, a sanitation system, a parks and recreation department, a planning and zoning department, and a staff to provide support (i.e., payroll processing, accounts payable, and revenue collection) to the service providers. The operation of each of these activities and entities is directly controlled by the City Council through the budgetary process.

The Mayor's Court (the Court), which provides judicial services, is responsible for the levying and collecting of fines and forfeitures under state and local laws, and their subsequent distribution to various government agencies. The City budgets and appropriates funds for the operation of the Court and is ultimately responsible for any operating deficits sustained by the Court. The City's share of the fines collected by the Court, along with its share of the Court's administrative and operating costs, is recorded in the City's General Fund. Due to this relationship, the Court is not considered a component unit of the City but rather as part of the primary government unit itself.

Component units are legally separate organizations for which the City is financially accountable. The City is financially accountable for an organization if the City appoints a voting majority of the organization's governing board and (1) the City is able to significantly influence the programs or services performed or provided by the organization; or (2) the City is legally entitled to or can otherwise access the organization's resources; the City is legally obligated or has otherwise assumed the responsibility to finance deficits of, or provide financial support to the organization. Component units may also include organizations that are fiscally dependent on the City in that the City approves the budget, the issuance of debt, or the levying of taxes. The City has no component units.

Jointly Governed Organizations

Southwest General Health Center

Southwest General Health Center is an Ohio nonprofit corporation providing health services. The Health Center is a jointly governed organization among the communities of Berea, Brook Park, Columbia Township, Middleburg Heights, Olmsted Falls and Strongsville.

The Health Center is governed by a Board of Trustees consisting of the following: one member of the legislative body from each of the political subdivisions, one resident from each of the political subdivisions who is not a member of the legislative body, three persons who are residents of any of the participating political subdivisions, the president and the executive vice president of the corporations, and the president and the vice president of the medical staff. The legislative body of each political subdivision elects their own member to serve on the Board of Trustees of the Health Center.

City of Brook Park, Ohio

Notes to the Basic Financial Statements (continued)

For The Year Ended December 31, 2019

Note 1: The Reporting Entity (continued)

Jointly Governed Organizations (continued)

The Board exercises total control over the operations of the Health Center including budgeting, appropriating, contracting and designating management. Each City's control is limited to its representation on the Board. In 2019, the City of Brook Park contributed \$111,522 of property tax levies and intergovernmental revenue to the Health Center.

Southwest Regional Communications

The Southwest Regional Communications is a jointly-governed organization between the City and seven other communities. Formed as a Regional Council of Governments as permitted under Ohio Revised Code Section 167.01, the intent of this organization is to establish, own, operate, maintain, and administer, a regional communications network for public safety and public service purposes for the mutual benefit of the participating communities. This organization is controlled by a governing body consisting of each participating community's mayor or his/her delegate or representative. The degree of control exercised by any member is limited to its representation on the governing board. All members agree to contribute the sums of money on a shared basis as agreed per the requirements set forth in the Articles of Understanding. In accordance with GASB Statement No. 14 as amended by GASB Statement No. 61, the City does not have an equity interest in the organization. Financial information may be obtained by writing to the Network Council, at 17401 Holland Road, Brook Park, Ohio 44142.

Note 2: Summary of Significant Accounting Policies

The financial statements of the City have been prepared in conformity with generally accepted accounting principles (GAAP) as applied to local governmental units. The Governmental Accounting Standards Board (GASB) is the accepted standard-setting body for establishing governmental accounting and financial principles. The most significant of the City's accounting policies are described below.

A. Basis of Presentation

The City's basic financial statements consist of government-wide statements, including a statement of net position and a statement of activities, and fund financial statements which provide a more detailed level of financial information.

Government-Wide Financial Statements

The statement of net position and the statement of activities display information about the City as a whole. These statements include the financial activities of the primary government, except for fiduciary funds. The activity of the internal service fund is eliminated to avoid doubling up revenues and expenses.

City of Brook Park, Ohio

Notes to the Basic Financial Statements (continued)

For The Year Ended December 31, 2019

Note 2: Summary of Significant Accounting Policies (continued)

A. *Basis of Presentation (continued)*

The statement of net position presents the financial condition of the governmental activities of the City at year-end. The statement of activities presents a comparison between direct expenses and program revenues for each program or function of the City's governmental activities. Direct expenses are those that are specifically associated with a service, program or department and therefore clearly identifiable to a particular function. Program revenues include charges paid by the recipient of the goods or services offered by the program, grants and contributions that are restricted to meeting the operational or capital requirements of a particular program and interest earned on grants that is required to be used to support a particular program. Revenues not classified as program revenues are presented as general revenues of the City, with certain limited exceptions. The comparison of direct expenses with program revenues identifies the extent to which each governmental function is self-financing or draws from the general revenues of the City.

Fund Financial Statements

During the year, the City segregates transactions related to certain City functions or activities in separate funds in order to aid financial management and to demonstrate legal compliance. Fund financial statements are designed to present financial information of the City at this more detailed level. The focus of governmental fund financial statements is on major funds. Each major fund is presented in a separate column. Non-Major funds are aggregated and presented in a single column. The internal service fund is presented in a single column on the face of the proprietary fund statements. Fiduciary funds are reported by type.

B. *Fund Accounting*

The City uses funds to maintain its financial records during the year. A fund is defined as a fiscal and accounting entity with a self-balancing set of accounts. There are three categories of funds: governmental, proprietary and fiduciary.

Governmental Funds

Governmental funds are those through which most governmental functions typically are financed. Governmental fund reporting focuses on the sources, uses and balances of current financial resources. Expendable assets are assigned to the various governmental funds according to the purposes for which they may or must be used. Current liabilities are assigned to the fund from which they will be paid. The difference between governmental fund assets and deferred outflows of resources compared to liabilities and deferred inflows of resources is reported as fund balance. The following are the City's major governmental funds:

General Fund

The General Fund accounts for all financial resources except those required to be accounted for in another fund. The General Fund balance is available to the City for any purpose provided it is expended or transferred according to the charter of the City and/or the general laws of Ohio.

City of Brook Park, Ohio

Notes to the Basic Financial Statements (continued)

For The Year Ended December 31, 2019

Note 2: Summary of Significant Accounting Policies (continued)

B. Fund Accounting (continued)

Capital Improvements Fund

The Capital Improvements Fund accounts for intergovernmental revenues, bond proceeds, and the portion of municipal income tax allocated by Council for the purpose of improving, constructing, maintaining, and purchasing those items necessary to enhance the operation of the City.

The other governmental funds of the City account for grants and other resources whose use is restricted, committed, or assigned to a particular purpose.

Proprietary Funds

Proprietary fund reporting focuses on the determination of operating income, changes in net position, financial position and cash flows. Proprietary funds are classified as either enterprise or internal service. The City has no enterprise funds.

Internal Service Fund

Internal service funds account for the financing of services provided by one department or agency to other departments or agencies of the City on a cost-reimbursement basis. The City's internal service fund reports on a self-insurance program for employee medical benefits.

Fiduciary Funds

Fiduciary fund reporting focuses on net position and changes in net position. The fiduciary fund category is split into four classifications: pension (and other employee benefit) trust funds, investment trust funds, private-purpose trust funds, and custodial funds. Trust funds are distinguished from custodial funds by the existence of a trust agreement or equivalent arrangements that have certain characteristics. Custodial funds are used to report fiduciary activities that are not required to be reported in a trust fund. The City's fiduciary fund is one custodial fund. The custodial fund is used to account for building code fees due to other governments.

C. Measurement Focus

Government-Wide Financial Statements

The government-wide financial statements are prepared using the economic resources measurement focus. All assets and deferred outflows of resources and all liabilities and deferred inflows of resources associated with the operation of the City are included on the Statement of Net Position, except for fiduciary funds. The Statement of Activities presents increases (e.g. revenues) and decreases (e.g. expenses) in total net position.

City of Brook Park, Ohio

Notes to the Basic Financial Statements (continued)

For The Year Ended December 31, 2019

Note 2: Summary of Significant Accounting Policies (continued)

C. *Measurement Focus (continued)*

Fund Financial Statements

All governmental funds are accounted for using a flow of current financial resources measurement focus. With this measurement focus, only current assets and deferred outflows of resources and current liabilities and deferred inflows of resources generally are included on the balance sheet. The statement of revenues, expenditures and changes in fund balances reports on the sources (i.e., revenues and other financing sources) and uses (i.e., expenditures and other financing uses) of current financial resources. This approach differs from the manner in which the governmental activities of the government-wide financial statements are prepared. Governmental fund financial statements therefore include reconciliations with brief explanations to better identify the relationship between the government-wide statements and the statements for governmental funds.

Like the government-wide statements, all proprietary funds are accounted for on a flow of economic resources measurement focus. All assets and deferred outflows of resources and all liabilities and deferred inflows of resources associated with the operation of these funds are included on the statement of net position. The statement of revenues, expenses and changes in net position presents increases (i.e., revenues) and decreases (i.e., expenses) in total net position. The statement of cash flows provides information about how the City finances and meets the cash flow needs of its proprietary activities.

D. *Basis of Accounting*

Basis of accounting determines when transactions are recorded in the financial records and reported on the financial statements. Government-wide financial statements are prepared using the accrual basis of accounting; proprietary and fiduciary funds also use the accrual basis of accounting. Governmental funds use the modified accrual basis of accounting. Differences in the accrual and modified accrual basis of accounting arise in the recognition of revenue, the recording of deferred outflows/inflows of resources, and in the presentation of expenses versus expenditures.

Revenues – Exchange and Non-Exchange Transactions

Revenue resulting from exchange transactions, in which each party gives and receives essentially equal value, is recorded on the accrual basis when the exchange takes place. On a modified accrual basis, revenue is recorded in the year in which the resources are measurable and become available. Available means that the resources will be collected within the current year or are expected to be collected soon enough thereafter to be used to pay liabilities of the current year. The available period for the City is sixty days after year-end.

City of Brook Park, Ohio

Notes to the Basic Financial Statements (continued)

For The Year Ended December 31, 2019

Note 2: Summary of Significant Accounting Policies (continued)

D. Basis of Accounting (continued)

Non-exchange transactions, in which the City receives value without directly giving equal value in return, include income taxes, property taxes, grants, entitlements and donations. On an accrual basis, revenue from income taxes is recognized in the period in which the income is earned. Revenue from property taxes is recognized in the year for which the taxes are levied (see Note 6). Revenue from grants, entitlements and donations is recognized in the year in which all eligibility requirements have been satisfied. Eligibility requirements include timing requirements, which specify the year when the resources are required to be used or the year when use is first permitted, matching requirements, in which the City must provide local resources to be used for a specified purpose, and expenditure requirements, in which the resources are provided to the City on a reimbursement basis. On a modified accrual basis, revenue from non-exchange transactions must also be available before it can be recognized.

Under the modified accrual basis, the following revenue sources are considered to be both measurable and available at year-end: income tax, state-levied locally shared taxes (including gasoline tax and motor vehicle license tax), fines and forfeitures, licenses and permits, interest, grants and entitlements and rentals.

Unearned revenue arises when assets are recognized before revenue recognition criteria have been satisfied.

Deferred Outflows/Inflows of Resources

In addition to assets, the statements of financial position will sometimes report a separate section for deferred outflows of resources. Deferred outflows of resources represent a consumption of net position that applies to a future period and will not be recognized as an outflow of resources (expense/expenditure) until then. For the City, deferred outflows of resources are reported on the government-wide statement of net position for pension/OPEB. A deferred charge on refunding results from the difference in the carrying value of refunded debt and its reacquisition price. The deferred outflows of resources related to pension and OPEB are explained in Notes 11, 12, and 13.

In addition to liabilities, the statements of financial position report a separate section for deferred inflows of resources. Deferred inflows of resources represent an acquisition of net position that applies to a future period and will not be recognized until that time. For the City, deferred inflows of resources include property taxes, pension, OPEB, and unavailable revenue. Property taxes represent amounts for which there is an enforceable legal claim as of December 31, 2019, but which were levied to finance year 2020 operations. These amounts have been recorded as a deferred inflow on both the government-wide statement of net position and governmental fund financial statements. Unavailable revenue is reported only on the governmental funds balance sheet and represents receivables which will not be collected within the available period. For the City, unavailable revenue includes delinquent property taxes, municipal income taxes, special assessments, intergovernmental, and charges for services. These amounts are deferred and recognized as an inflow of resources in the period the amounts become available. Deferred inflows of resources related to pension and OPEB plans are reported on the government-wide statement of net position. (See Note 11, 12, and 13)

City of Brook Park, Ohio

Notes to the Basic Financial Statements (continued)

For The Year Ended December 31, 2019

Note 2: Summary of Significant Accounting Policies (continued)

D. Basis of Accounting (continued)

Expenses/Expenditures

On the accrual basis of accounting, expenses are recognized at the time they are incurred.

The measurement focus of governmental fund accounting is on decreases in net financial resources (expenditures) rather than expenses. Expenditures are generally recognized in the accounting period in which the related fund liability is incurred, if measurable. Allocations of cost, such as depreciation and amortization, are not recognized in governmental funds.

E. Budgetary Process

An annual appropriated budget is legally required to be prepared for all funds of the City other than agency funds. Council passes appropriations at the department level by object. Line item appropriations may be transferred between the accounts with the approval of the Finance Director and respective department head. Council must approve any revisions in the budget that alter total fund appropriations. The following are the procedures used by the City in establishing the budgetary data reported in the basic financial statements:

Tax Budget

A tax budget of estimated revenue and expenditures for all funds other than agency funds is submitted to the County Auditor, as Secretary of the County Budget Commission, by July 20th of each year, for the period January 1 to December 31 of the following year.

Estimated Resources

The County Budget Commission determines if the budget substantiates a need to levy the full amount of authorized property tax rates and reviews revenue estimates. The Commission certifies its actions to the City by September 1. As part of this certification, the City receives the official certificate of estimated resources, which states the projected revenue of each fund. Prior to December 31, the City must revise its budget so that the total contemplated expenditures from any fund during the ensuing fiscal year will not exceed the amount available as stated in the certificate of estimated resources. The revised budget then serves as the basis for the annual appropriations measure.

On or about January 1 the certificate of estimated resources is amended to include unencumbered fund balances at December 31. Further amendments may be made during the year if the Finance Director determines that revenue to be collected will be greater than or less than the prior estimates and the budget commission considers the revised estimates to be reasonable. The amounts reported in the budgetary statements as original represent the amounts in the first official certificate of estimated resources issued during 2019. The amounts reported in the budgetary statements as final reflect the amounts in the final amended official certificate of estimated resources issued during 2019.

City of Brook Park, Ohio

Notes to the Basic Financial Statements (continued)

For The Year Ended December 31, 2019

Note 2: Summary of Significant Accounting Policies (continued)

E. Budgetary Process (continued)

Annual Estimate

The Mayor, with the assistance of the Finance Director, is required by Charter to submit to Council, on or before December 1 of each fiscal year, an estimate of the revenues and expenditures of each fund of the City for the next succeeding fiscal year. The annual estimate serves as the basis for appropriations (the appropriated budget) in each fund.

Appropriations

An appropriation ordinance (the appropriated budget) to control the level of expenditures for all funds must be legally enacted on or about January 1. Appropriations may not exceed estimated resources as established in the official Amended Certificate of Estimated Resources. Supplemental appropriations may be adopted by Council action. During the year, several supplemental appropriation measures were necessary. The amounts reported as the original budgeted amounts in the budgetary statements reflect the first appropriated budget for each fund that covered the entire year, including amounts automatically carried over from prior years. The amounts reported as the final budgeted amounts in the statements of budgetary comparisons represent the final appropriation amounts, including all amendments and modifications.

Lapsing of Appropriations

At the close of each year, the unencumbered balance of each appropriation reverts to the respective fund from which it was appropriated and becomes subject to future appropriations. The encumbered appropriation balance is carried over for the subsequent year's expenditures and is re-appropriated.

Budgeted Level of Expenditure

Administrative control is maintained through the establishment of detailed line-item budgets. Appropriated funds may not be expended for purposes other than those designated in the appropriation ordinance without authority from Council. Expenditures plus encumbrances may not legally exceed appropriations at the level of appropriation adopted by Council. For all funds, Council appropriations are made at the department level by object. The appropriations set by Council must remain fixed unless amended by Council ordinance. More detailed appropriation allocations may be made by the Finance Director as long as the allocations are within Council's appropriated amount.

Encumbrances

As part of formal budgetary control, purchase orders, contracts, and other commitments for the expenditure of monies are encumbered and recorded as the equivalent of expenditures on the non-GAAP budgetary basis in order to reserve that portion of the applicable appropriation and determine and maintain legal compliance. The Ohio Revised Code prohibits expenditures plus encumbrances from exceeding appropriations. Encumbrances outstanding at year-end are reported as part of restricted, committed, and assigned fund balances for subsequent-year expenditures of governmental funds.

City of Brook Park, Ohio

Notes to the Basic Financial Statements (continued)

For The Year Ended December 31, 2019

Note 2: Summary of Significant Accounting Policies (continued)

F. Pooled Cash and Cash Equivalents

To improve cash management, cash received by the City is pooled. Monies for all funds are maintained in this pool. Individual fund integrity is maintained through City records. Each fund's interest in the pool is presented as "equity in pooled cash and cash equivalents" on the balance sheet.

The City has segregated bank accounts for monies held separate from the City's cash pool. These depository accounts are presented as "cash and cash equivalents in segregated accounts" since they are not required to be deposited into the City's treasury and are related to the City's mayor's court.

Investments are reported at fair value which is based on quoted market prices. Non-participating contracts such as non-negotiable certificates of deposits are reported at cost.

During fiscal year 2019, the City invested in STAR Ohio. STAR Ohio (the State Treasury Asset Reserve of Ohio), is an investment pool managed by the State Treasurer's Office which allows governments within the State to pool their funds for investment purposes.

STAR Ohio is not registered with the SEC as an investment company, but has adopted Governmental Accounting Standards Board (GASB), Statement No. 79 "Certain External Investment Pools and Pool Participants." The City measures their investment in STAR Ohio at the net asset value (NAV) per share provided by STAR Ohio. The NAV per share is calculated on an amortized cost basis that provides a NAV per share that approximates fair value.

For 2019, there were no limitation or restrictions on any participant withdrawals due to redemption notice periods, liquidity fees, or redemption gates. However, notice must be given 24 hours in advance of all deposits and withdrawals exceeding \$25 million. STAR Ohio reserves the right to limit the transaction to \$100 million, requiring the excess amount to be transacted the following business day(s), but only to the \$100 million limit. All accounts of the participant will be combined for these purposes.

The City's policy is to hold investments until fair values equal or exceed cost.

Interest allocation is determined by the Ohio Constitution, state statutes, and local ordinances adopted under City Charter. Under these provisions, City funds required to receive interest allocations are: 1) those which receive monies from confiscated property from federal task forces and 2) those which receive distributions of state gasoline tax and motor vehicle licenses fees (street maintenance, state highway, and permissive tax special revenue funds). All remaining interest is allocated to the general fund. Legally, proprietary funds generally do not receive interest. Interest revenue credited to the General Fund during 2019 amounted to \$162,760, which includes \$63,340 assigned from other funds.

City of Brook Park, Ohio

Notes to the Basic Financial Statements (continued)

For The Year Ended December 31, 2019

Note 2: Summary of Significant Accounting Policies (continued)

G. Inventory

Inventories are stated at cost, on the first-in, first-out basis. The purchase method is used to account for inventories. Under the purchase method, inventories are recorded as expenditures in the governmental fund types when purchased; however, material amounts of inventories at period-end are reported as assets of the respective fund, which are equally offset in the non-spendable component of fund balance which indicates they are unavailable for appropriation even though they are a component of reported assets. Inventory consists of expendable supplies.

H. Prepaid Items

Payments made to vendors for services that will benefit periods beyond December 31, 2019, are recorded as prepaid items using the allocation method by recording a current asset for the prepaid amount and reflecting the expenditure/expense in the year in which it was consumed.

I. Receivables

Receivables at December 31, 2019 consist of taxes, intergovernmental, accounts (billings for user charged services), special assessments, and accrued interest on investments. All are deemed collectible in full.

J. Capital Assets

General capital assets are those assets not specifically related to activities reported in the proprietary funds. These assets generally result from expenditures in the governmental funds. These assets are reported in the governmental activity's column of the government-wide statement of net position but are not reported in the fund financial statements.

All capital assets are capitalized at cost (or estimated historical cost) and updated for additions and disposals during the year. Donated capital assets are recorded at their acquisition value as of the date received. The City maintains a capitalization threshold of five thousand dollars. The City's infrastructure consists of bridges, culverts, curbs, sidewalks, storm sewers, streets, irrigation systems and water and sewer lines. Improvements are capitalized; the costs of normal maintenance and repairs that do not add to the value of the asset or materially extend an asset's life are not. Interest incurred during the construction of capital assets is also capitalized.

All capital assets are depreciated except for land and construction in progress. Improvements are depreciated over the remaining useful lives of the related capital assets. Useful lives for infrastructure were estimated based on the City's historical records of necessary improvements and replacement. Depreciation is computed using the straight-line method over the following useful lives:

<u>Description</u>	<u>Estimated Lives</u>
Buildings and Improvements	50 years
Machinery and Equipment	10 to 15 years
Vehicles	6 to 10 years
Infrastructure	25 to 50 years

City of Brook Park, Ohio

Notes to the Basic Financial Statements (continued)

For The Year Ended December 31, 2019

Note 2: Summary of Significant Accounting Policies (continued)

K. Interfund Balances

On fund financial statements, outstanding interfund loans and unpaid amounts for interfund services are reported as “interfund receivables/payables”. Interfund loans which do not represent available expendable resources would be offset by a component of fund balance. Interfund balance amounts are eliminated in the statement of net position.

L. Compensated Absences

The City reports compensated absences in accordance with the provisions of GASB No. 16, “*Accounting for Compensated Absences*.” Vacation benefits are accrued as a liability as the benefits are earned if the employees’ rights to receive compensation are attributable to services already rendered and it is probable that the employer will compensate the employees for the benefits through paid time off or some other means.

Sick leave benefits are accrued as a liability using the vesting method. The liability includes the employees who are currently eligible to receive termination benefits and those that the City has identified as probable of receiving payment in the future. The amount is based on accumulated sick leave and employee wage rates at fiscal year-end taking into consideration any limits specified in the City’s termination policy.

Additionally, certain salary related payments associated with the payment of compensated absences have been accrued.

The entire compensated absence liability is reported on the government-wide financial statements. A liability for the amounts is reported in governmental funds only if they have matured, for example, as a result of employee resignations and retirements.

M. Pensions/Other Postemployment Benefits (OPEB)

For purposes of measuring the net pension/OPEB liability, net pension asset, deferred outflows of resources and deferred inflows of resources related to pensions/OPEB, and pension/OPEB expense, information about the fiduciary net position of the pension/OPEB plans and additions to/deductions from their fiduciary net position have been determined on the same basis as they are reported by the pension/OPEB plan. For this purpose, benefit payments (including refunds of employee contributions) are recognized when due and payable in accordance with the benefit terms. The pension/OPEB plans report investments at fair value.

N. Accrued Liabilities and Long-Term Obligations

All payables, accrued liabilities and long-term obligations are reported in the government-wide financial statements.

In general, governmental fund payables and accrued liabilities that, once incurred, are paid in a timely manner and in full from current financial resources are reported as obligations of the funds. However, claims and judgments and compensated absences that will be paid from governmental funds are reported as a liability in the fund financial statements only to the extent that they are due for payment during the current year. Bonds, capital leases and long-term loans are recognized as a liability on the governmental fund financial statements when due.

City of Brook Park, Ohio

Notes to the Basic Financial Statements (continued)

For The Year Ended December 31, 2019

Note 2: Summary of Significant Accounting Policies (continued)

O. Fund Balance

Fund balance is divided into five classifications based primarily on the extent to which the City is bound to observe constraints imposed upon the use of the resources in the governmental funds. The classifications are as follows:

Nonspendable – The nonspendable fund balance classification includes amounts that cannot be spent because they are not spendable in form, or legally or contractually required to be maintained intact. The “not in spendable form” criterion includes items that are not expected to be converted to cash. It also includes the long-term amount of loans receivable, as well as property acquired for resale, unless the use of the proceeds from the collection of those receivables or from the sale of those properties is restricted, committed, or assigned.

Restricted – Fund balance is reported as restricted when constraints placed on the use of resources are either externally imposed by creditors (such as through debt covenants), grantors, contributors, or laws or regulations of other governments or is imposed by law through constitutional provisions.

Committed – The committed fund balance classification includes amounts that can be used only for the specific purposes imposed by a formal action (ordinance) of the City’s Council. Those committed amounts cannot be used for any other purpose unless the City’s Council removes or changes the specified use by taking the same type of action (ordinance) it employed to previously commit those amounts. Committed fund balance also incorporates contractual obligations to the extent that existing resources in the fund have been specifically committed for use in satisfying those contractual requirements.

Assigned – Amounts in the assigned fund balance classification are intended to be used by the City for specific purposes but do not meet the criteria to be classified as restricted or committed. In governmental funds other than the general fund, assigned fund balance represents the remaining amount that is not restricted or committed. These amounts are assigned by the City Council. In the general fund, assigned amounts would represent intended uses established by policies of the City Council or a City official delegated that authority by City Charter or ordinance, or by State statute. State statute authorizes the finance director to assign fund balance for purchases on order provided such amounts have been lawfully appropriated.

Unassigned – Unassigned fund balance is the residual classification for the general fund and includes all spendable amounts not contained in the other classifications. In the other governmental funds, the unassigned classification is used only to report a deficit balance resulting from overspending for specific purposes for which amounts had been restricted, committed, or assigned.

The City applies restricted resources first when expenditures are incurred for purposes for which either restricted or unrestricted (committed, assigned, and unassigned) amounts are available. Similarly, within unrestricted fund balance, committed amounts are reduced first followed by assigned, and then unassigned amounts when expenditures are incurred for purposes for which amounts in any of the unrestricted fund balance classifications could be used.

City of Brook Park, Ohio

Notes to the Basic Financial Statements (continued)

For The Year Ended December 31, 2019

Note 2: Summary of Significant Accounting Policies (continued)

P. Net Position

Net position is the residual amount when comparing assets and deferred outflows of resources to liabilities and deferred inflows of resources. The net investment in capital assets component of net position consists of capital assets, net of accumulated depreciation, reduced by the outstanding balances of any borrowing used for the acquisition, construction or improvement of those assets along with any related deferred outflows/inflows of resources. The restricted component of net position is reported when there are limitations imposed on their use either through the enabling legislation adopted by the City or through external restrictions imposed by creditors, grantors or laws or regulations of other governments. As of December 31, 2019, the City did not have net position restricted by enabling legislation.

The City applies restricted resources when an expense is incurred for purposes for which both restricted and unrestricted net position are available.

Q. Grants and Intergovernmental Revenues

Federal grants and assistance awards made on the basis of entitlement periods are recorded as intergovernmental receivables and revenues when entitlement occurs. Federal reimbursement-type grants are recorded as intergovernmental receivables and revenues in the period when all applicable eligibility requirements have been met and the resources are available.

R. Interfund Activity

Exchange transactions between funds are reported as revenues in the seller funds and as expenditures/expenses in the purchaser funds. Flows of cash or goods from one fund to another without a requirement for repayment are reported as interfund transfers. Interfund transfers are reported as other financing sources/uses in governmental funds and after nonoperating revenues/expenses in proprietary funds. Repayments from funds responsible for particular expenditures/expenses to the funds that initially paid for them are not presented on the financial statements.

S. Extraordinary and Special Items

Extraordinary items are transactions or events that are both unusual in nature and infrequent in occurrence. Special items are transactions or events that are within the control of the City Administration and that are either unusual in nature or infrequent in occurrence. Neither extraordinary nor special items had occurred in 2019.

T. Estimates

The preparation of the financial statements in conformity with generally accepted accounting principles requires management to make estimates and assumptions that affect the amounts reported in the financial statements and accompanying notes. Actual results may differ from those estimates.

City of Brook Park, Ohio

Notes to the Basic Financial Statements (continued)

For The Year Ended December 31, 2019

Note 3: Change in Accounting Principles

During the year, the City implemented the following Governmental Accounting Standards Board (GASB) Statements:

GASB Statement No. 90, *Majority Equity Interests – an amendment of GASB Statements No. 14 and No. 61*. The primary objectives of this Statement are to improve the consistency and comparability of reporting a government's majority equity interest in a legally separate organization and to improve the relevance of financial statements information for certain component units. The implementation of this Statement did not have an effect on the financial statements of the City.

GASB Statement No. 84, *Fiduciary Activities*. This Statement established specific criteria for identifying activities that should be reported as fiduciary activities and clarifies whether and how business-type activities should report their fiduciary activities. The City reviewed its fiduciary funds and certain funds will be reported in the new fiduciary fund classification of custodial funds while other funds have been reclassified as governmental funds. These changes were incorporated in the City's 2019 financial statements; however, there was no effect on the beginning net position/fund balance.

GASSB Statement No. 95, *Postponement of the Effect Dates of Certain Authoritative Guidance*. The primary objective of this Statement is to provide temporary relief to governments and other stakeholders in light of the COVID-19 pandemic. That objective is accomplished by postponing the effective dates of certain provisions in Statements and Implementation Guides that first became effective or are scheduled to become effective for periods beginning after June 15, 2018, and later. The City has postponed the implementation of GASB Statement No. 83 and GASB Statement No. 88.

City of Brook Park, Ohio

Notes to the Basic Financial Statements (continued)

For The Year Ended December 31, 2019

Note 4: Budgetary Basis of Accounting

While the City is reporting financial position, results of operations, and changes in fund balances on the basis of generally accepted accounting principles (GAAP), the budgetary basis as provided by law is based upon accounting for certain transactions on a basis of cash receipts, disbursements, and encumbrances.

The Statements of Revenues, Expenditures and Changes in Fund Balances – Budget (Non-GAAP Budgetary Basis) and Actual presented for the General Fund is presented on the budgetary basis to provide a meaningful comparison of actual results with the budget. The major differences between the budget basis and the GAAP basis are that:

- (a) Revenues are recorded when received in cash (budget basis) as opposed to when susceptible to accrual (GAAP basis);
- (b) Expenditures are recorded when paid in cash (budget basis) as opposed to when the liability is incurred (GAAP basis);
- (c) Encumbrances are treated as expenditures (budget) rather than as a part of restricted, committed, and assigned fund balances (GAAP);
- (d) Some funds are included in the General Fund (GAAP basis), but have separate legally adopted budgets (budget basis).

The following table summarizes the adjustments necessary to reconcile the GAAP basis statements to the budgetary basis statements for the General Fund.

<u>Net Change in Fund Balance</u>	
	<u>General</u>
GAAP Basis	\$ 2,113,803
Increase (Decrease) Due to:	
Revenue Accruals	215,439
Expenditure Accruals	(333,680)
Funds with Separate Legally Adopted Budget	(30,872)
Outstanding Encumbrances	<u>(197,320)</u>
Budget Basis	<u>\$ 1,767,370</u>

Note 5: Deposits and Investments

State statutes classify monies held by the City into three categories. Active deposits are public deposits necessary to meet current demands on the treasury. Such monies must be maintained either as cash in the City treasury, in commercial accounts payable or withdrawable on demand, including negotiable order of withdrawal (NOW) accounts, or in money market deposit accounts.

Inactive deposits are monies identified as not required for use within the current five-year period of designation of depositories. Inactive deposits must either be evidenced by certificates of deposit maturing not later than the end of the current period of designation of depositories, or by savings or deposit account including, but not limited to, passbook accounts.

City of Brook Park, Ohio

Notes to the Basic Financial Statements (continued)

For The Year Ended December 31, 2019

Note 5: Deposits and Investments (continued)

Interim monies are those monies which are not needed for immediate use but which will be needed before the end of the current period of designation of depositories. Interim monies may be deposited or invested in the following securities:

1. United States Treasury notes, Bills, Bonds, or any other obligation or security issued by the United States Treasury or any other obligation guaranteed as to principal and interest by the United States;
2. Bonds, notes, debentures, or any other obligations or securities issued by any federal government agency or instrumentality, including but not limited to, the Federal National Mortgage Association, Federal Home Loan Bank, Federal Farm Credit Bank, Federal Home Loan Mortgage Corporation, Government National Mortgage Association, and Student Loan Marketing Association. All federal agency securities shall be direct issuances of federal government agencies or instrumentalities;
3. Written repurchase agreements in the securities listed above provided that the fair value of the securities subject to the repurchase agreement must exceed the principal value of the agreement by at least two percent and be marked to market daily;
4. Investment grade obligations of state and local governments, and public authorities;
5. No-load money market mutual funds consisting exclusively of obligations described in division (1) or (2) of this section and repurchase agreements secured by such obligations, provided that investments in securities described in this division are made only through eligible institutions; and
6. The State Treasurer's investment pool (STAR Ohio).

Investments in stripped principal or interest obligations, reverse repurchase agreements and derivatives are prohibited. The issuance of taxable notes for the purpose of arbitrage, the use of leverage and short selling are also prohibited. An investment must mature within five years from the date of purchase unless matched to a specific obligation or debt of the City and must be purchased with the expectation that it will be held to maturity.

Investments may only be made through specified dealers and institutions. Payment for investments may be made only upon delivery of the securities representing the investments to the treasurer or qualified trustee or, if the securities are not represented by a certificate, upon receipt of confirmation of transfer from the custodian.

City of Brook Park, Ohio

Notes to the Basic Financial Statements (continued)

For The Year Ended December 31, 2019

Note 5: Deposits and Investments (continued)

A. Cash on Hand

At December 31, 2019, the City had \$4,030 in undeposited cash on hand, which is included on the balance sheet of the City as part of "Equity in Pooled Cash and Cash Equivalent."

B. Deposits

At year-end, the carrying amount of the City's deposits was \$14,210,225 (including \$39,482 of segregated accounts) and the bank balance was \$14,855,231. As of December 31, 2019, \$263,058 of the City's bank balances were covered by Federal depository insurance and the remaining \$14,592,173 was exposed to custodial credit risk because it was uninsured and collateralized. Although the securities were held by the pledging institution's trust department and all statutory requirements for the investment of money had been followed, noncompliance with Federal requirements could potentially subject the City to a successful claim by the FDIC.

The City has no deposit policy for custodial risk beyond the requirements of State statute. Ohio law requires that deposits be either insured or protected by:

Eligible securities pledged to the City and deposited with a qualified trustee by the financial institution as security for repayment whose fair value at all times shall be at least 105 percent of the deposits being secured; or

Participation in the Ohio Pooled Collateral System (OPCS), a collateral pool of eligible securities deposited with a qualified trustee and pledged to the Treasurer of State to secure the repayment of all public monies deposited in the financial institution. OPCS requires the total fair value of the securities pledged to be 102 percent of the deposits being secured or a rate set by the Treasurer of State. The City's financial institution had enrolled in OPCS as of December 31, 2019.

C. Investments

Investments are reported at Net Asset Value. As of December 31, 2019, the City had the following investments:

<u>Investment Type</u>	<u>NAV</u>	<u>Credit Rating (*)</u>	<u>Investment Maturities (in Years)</u>
STAR Ohio	\$ 7,963,559	AAAm	<1
Total Investments	<u>\$ 7,963,559</u>		<u>\$ 7,963,559</u>

* Credit Ratings were obtained from Standard & Poor's, respectively, for all investments.

The City has categorized its fair value measurements within the fair value hierarchy established by generally accepted accounting principles. The hierarchy is based on the valuation inputs used to measure the fair value of the asset. Level 1 inputs are quoted prices in active markets for identical assets. Level 2 inputs are significant other observable inputs; Level 3 inputs are significant unobservable inputs.

City of Brook Park, Ohio

Notes to the Basic Financial Statements (continued)

For The Year Ended December 31, 2019

Note 5: Deposits and Investments (continued)

C. Investments (continued)

Interest Rate Risk arises because potential purchasers of debt securities will not agree to pay face value for those securities if interest rates subsequently increase. The City's investment policy addresses interest rate risk requiring that the City's investment portfolio be structured so that securities mature to meet cash requirements for ongoing operations and/or long-term debt payments, thereby avoiding that need to sell securities on the open market prior to maturity and by investing operating funds primarily in short-term investments. The City's investment policy also limits security purchases to those that mature in five years unless specifically matched to a specific cash flow. To date, no investments have been purchased with a life greater than five years.

Custodial Risk for investments is the risk that, in the event of the failure of the counterparty to a transaction, the City will not be able to recover the value of investment or collateral securities that are in the possession of an outside party. All financial institutions and broker/dealers who desire to become qualified for investment transactions with the City must meet a set of prescribed standards and be periodically reviewed.

Credit Risk is addressed by the City's investment policy by the requirements that all investments are authorized by Ohio Revised Code and that the portfolio be diversified both by types of investment and issuer. The investments of the City are registered and the credit rating provided by Standard & Poor's is provided in the table above.

Concentration of Credit Risk is defined by the Governmental Accounting Standards Board as five percent or more in the securities of a single issuer. The City's investment policy requires diversification of the portfolio but does not indicate specific percentage allocations. The City's investment in STAR Ohio represents 100.00 percent of the City's total investments.

Note 6: Receivables

Receivables at December 31, 2019 consisted primarily of taxes, intergovernmental receivables arising from grants, entitlements or shared revenues, accounts, special assessments and interest on investments. All receivables are considered fully collectible.

A. Property Tax

Property taxes include amounts levied against all real, public utility, and tangible personal property located in the City. Taxes collected on real property (other than public utility) in one calendar year are levied in the preceding calendar year on assessed values as of January 1 of that preceding year, the lien date. Assessed values are established by state statute at 35 percent of appraised market value. All property is required to be revalued every six years. The last revaluation was completed in 2019. Real property taxes are payable annually or semiannually. The first payment is due December 31, with the remainder payable by June 20.

Taxes collected on tangible personal property (other than public utility) in one calendar year are levied in the prior calendar year on assessed values during and at the close of the most recent fiscal year of the taxpayer that ended on or before March 31 of that calendar year, and at the tax rates determined in the preceding year.

City of Brook Park, Ohio

Notes to the Basic Financial Statements (continued)

For The Year Ended December 31, 2019

Note 6: Receivables (continued)

A. Property Tax (continued)

Tangible personal property used in business (except for public utilities) is currently assessed for *ad valorem* taxation purposes at 25 percent of its true value. The tangible personal property tax has been phased out and the City is only receiving residual amounts from delinquent tangible personal property taxes.

Amounts paid by multi-county taxpayers are due September 20. Single county taxpayers may pay annually or semiannually. If paid annually, payment is due April 30; if paid semiannually, the first payment is due April 30; with the remainder payable by September 20.

Public utility real and tangible personal property taxes collected in one calendar year are levied in the preceding calendar year on assessed values determined as of December 31 of the second year preceding the tax collection year, the lien date. Certain public utility tangible personal property currently is assessed at 88 percent of its true value. Public utility property taxes are payable on the same dates as real property taxes described previously.

The County Fiscal Officer collects property taxes on behalf of all taxing districts in the county, including the City of Brook Park. The County Fiscal Officer periodically remits to the City its portion of the taxes collected.

The full tax rate for all City operations for the year ended December 31, 2019, was \$4.75 per \$1,000 of assessed value. The assessed values of real and tangible personal property upon which 2019 property tax receipts were based are as follows:

<u>Category</u>	<u>Assessed Value</u>
Real Estate	\$ 437,366,980
Public Utility	13,748,880
Total	<u>\$ 451,115,860</u>

B. Income Tax

The City levies and collects a 2 percent income tax on all income earned within the City as well as on income of residents earned outside the City. In the latter case, the City allows a credit of 100 percent of the tax paid to another municipality, not to exceed the amount owed. Employers within the City are required to withhold income tax on employee earnings and remit the tax to the City at least quarterly. Corporations and other individual taxpayers are also required to pay their estimated tax at least quarterly and file a final return annually. The City, by ordinance, allocates income tax revenues and expenditures for collecting, administering, and enforcing the tax to the General and Capital Improvements Funds, at eighty and twenty percent, respectively.

The Capital Improvements Fund further allocates income taxes to other project-based capital projects funds, as transfers, through the budgetary process.

City of Brook Park, Ohio

Notes to the Basic Financial Statements (continued)

For The Year Ended December 31, 2019

Note 6: Receivables (continued)

C. Intergovernmental

A summary of the principal items of intergovernmental receivables follows:

	<u>Amounts</u>
Local government funds	\$ 194,753
Homestead and rollback	117,216
Gasoline and excise tax	509,340
Permissive tax	3,711
Grants	2,765
City of Cleveland (share of OPWC loan)	633,534
Miscellaneous Grant	50,000
Total	<u>\$ 1,511,319</u>

This space is intentionally left blank

City of Brook Park, Ohio

Notes to the Basic Financial Statements (continued)

For The Year Ended December 31, 2019

Note 7: Capital Assets

	Balances 12/31/2018	Additions	Disposals	Balances 12/31/2019
Governmental Activities				
Nondepreciable Assets:				
Land	\$ 4,926,923	\$ -	\$ (1,901,344)	\$ 3,025,579
Construction in progress	5,495,383	1,961,232	(5,472,606)	1,984,009
Total Nondepreciable Assets	<u>10,422,306</u>	<u>1,961,232</u>	<u>(7,373,950)</u>	<u>5,009,588</u>
Depreciable Assets:				
Buildings and Improvements	22,861,368	134,536	-	22,995,904
Improvements Other than Buildings	3,185,667	-	(34,585)	3,151,082
Machinery and Equipment	5,259,654	154,335	-	5,413,989
Furniture and Fixtures	218,050	-	-	218,050
Vehicles	10,117,846	97,748	(464,229)	9,751,365
Infrastructure:				
Streets	58,273,554	5,472,606	-	63,746,160
Sewers	28,283,759	-	-	28,283,759
Water Lines	1,748,475	-	-	1,748,475
Total Depreciable Assets	<u>129,948,373</u>	<u>5,859,225</u>	<u>(498,814)</u>	<u>135,308,784</u>
Less Accumulated Depreciation				
Buildings and Improvements	(11,837,331)	(1,795,402)	-	(13,632,733)
Improvements Other than Buildings	(2,546,706)	(110,469)	25,218	(2,631,957)
Machinery and Equipment	(4,108,555)	(235,431)	-	(4,343,986)
Furniture and Fixtures	(196,825)	(5,020)	-	(201,845)
Vehicles	(6,751,643)	(463,383)	462,929	(6,752,097)
Infrastructure:				
Streets	(19,958,933)	(1,893,479)	-	(21,852,412)
Sewers	(10,375,899)	(565,675)	-	(10,941,574)
Water Lines	(433,343)	(33,095)	-	(466,438)
Total Accumulated Depreciation	<u>(56,209,235)</u>	<u>(5,101,954)*</u>	<u>488,147</u>	<u>(60,823,042)</u>
Total Depreciable Assets, Net	<u>73,739,138</u>	<u>757,271</u>	<u>(10,667)</u>	<u>74,485,742</u>
Governmental Activities Capital Assets, Net	<u>\$ 84,161,444</u>	<u>\$ 2,718,503</u>	<u>\$ (7,384,617)</u>	<u>\$ 79,495,330</u>

* Depreciation was charged to governmental activities as follows:

Security of Persons and Property:	
Police and Others	\$ 175,669
Fire	153,729
Public Health and Welfare	1,167
Leisure Time Activities	1,745,951
Community Development	19,269
Public Works	985,745
Transportation	1,852,408
General Government	168,016
Total Depreciation Expense	<u>\$ 5,101,954</u>

City of Brook Park, Ohio

Notes to the Basic Financial Statements (continued)

For The Year Ended December 31, 2019

Note 8: Long-Term Obligations

The original issue date, interest rates, and original issuance amount for each of the City's general obligation bonds follow:

	Original Issuance Date	Interest Rate	Original Issuance Amount
General Obligation Bonds:			
Laich Street Improvements	2004	2% - 3.7%	\$ 775,000
Heatherwood Dr. Reconstruction	2011	2% - 3.4%	905,000
Sheldon Rd. Waterline Replacement	2011	2% - 3.4%	800,000
Various Purpose Improvement Bonds:			
Engle Road Resurfacing	2013	2% - 4.75%	1,835,000
Engle Road Sanitary Sewer Replacement	2013	2% - 4.75%	1,965,000
Smith Road Sanitary Sewer	2013	2% - 4.75%	1,720,000
Energy Conservation Improvement Bonds	2017	1%- 4%	4,980,000

Changes in long-term debt activity for the year ended December 31, 2019 was as follows:

	Balances 12/31/2018	Issued	Retired	Balances 12/31/2019	Amounts Due in One Year
General Obligation Bonds:					
Laich Street Improvements	\$ 300,000	\$ -	\$ 45,000	\$ 255,000	\$ 45,000
Heatherwood Drive Reconstruction	530,000	-	60,000	470,000	60,000
Sheldon Rd. Waterline Replacement	465,000	-	50,000	415,000	55,000
Various Purpose Improvement Bonds, Series 2013:					
Engle Road Resurfacing Project	1,325,000	-	110,000	1,215,000	115,000
Engle Road Sanitary Sewer Replacement Project	1,600,000	-	80,000	1,520,000	80,000
Smith Road Sanitary Sewer Project	1,405,000	-	70,000	1,335,000	70,000
Energy Conservation Improvement Project	4,700,000	-	155,000	4,545,000	165,000
Total General Obligation Bonds	<u>10,325,000</u>	<u>-</u>	<u>570,000</u>	<u>9,755,000</u>	<u>590,000</u>
Capitalized Lease Agreements:					
Safety Forces Vehicles	87,311	-	87,311	-	-
Sewer Vector	668,354	-	127,789	540,565	130,665
Service Equipment	49,478	-	49,478	-	-
Various Vehicles	216,987	-	216,987	-	-
Total Capital Leases	<u>1,022,130</u>	<u>-</u>	<u>481,565</u>	<u>540,565</u>	<u>130,665</u>

(continued)

City of Brook Park, Ohio

Notes to the Basic Financial Statements (continued)

For The Year Ended December 31, 2019

Note 8: Long-Term Obligations (continued)

	Balances		Balances		Amounts
	12/31/2018	Issued	Retired	12/31/2019	Due in One Year
Other Long-term Obligations:					
OPWC Loans:					
W. 150th Project	\$ 1,120,863	\$ -	\$ 97,467	\$ 1,023,396	\$ 48,733
Smith/Hummel Rd	76,790	-	5,907	70,883	2,953
Smith Rd. Sanitary Sewer	742,612	-	40,141	702,471	20,071
City of Berea - Eastland Rd.	517,045	-	32,315	484,730	16,158
Holland Road Reconstruction	-	106,689	-	106,689	-
Total OPWC Loans Payable	<u>2,457,310</u>	<u>106,689</u>	<u>175,830</u>	<u>2,388,169</u>	<u>87,915</u>
Unamortized Bond Premiums	393,111	-	27,152	365,959	-
Accrued Compensated Absences	2,208,376	716,855	374,091	2,551,140	611,793
Net Pension Liability:					
OPERS (See Note 11)	6,398,062	4,381,844	-	10,779,906	-
OP&F (See Note 11)	17,394,397	5,787,426	-	23,181,823	-
Total Net Pension Liability:	<u>23,792,459</u>	<u>10,169,270</u>	<u>-</u>	<u>33,961,729</u>	<u>-</u>
Net OPEB Liability					
OPERS (See Note 12)	4,194,933	666,672	-	4,861,605	-
OP&F (See Note 12)	16,057,841	-	13,471,588	2,586,253	-
Other OPEB (See Note 13)	1,835,770	-	157,304	1,678,466	-
Total Net OPEB Liability	<u>22,088,544</u>	<u>666,672</u>	<u>13,628,892</u>	<u>9,126,324</u>	<u>-</u>
Total Other Long-term Obligations	<u>50,939,800</u>	<u>11,659,486</u>	<u>14,205,965</u>	<u>48,393,321</u>	<u>699,708</u>
Total Governmental					
Long-term Liabilities	<u>\$ 62,286,930</u>	<u>\$ 11,659,486</u>	<u>\$ 15,257,530</u>	<u>\$ 58,688,886</u>	<u>\$ 1,420,373</u>

General obligation bonds are direct obligations of the City for which its full faith and credit are pledged for repayment. In the event that income tax revenues are not sufficient to meet annual principal and interest requirements, the City has reserved the right to levy and assess a special assessment on the property. Revenues will be received in and the debt will be paid from the General Obligation Debt Service Fund.

During 2005, the Ohio Public Works Commission (OPWC) approved a loan to the City to finance a portion of the West 150th Street Improvement project. OPWC committed up to \$1,949,332 at a zero percent interest rate for twenty years. The City and the City of Cleveland have an agreement to share the debt service requirements of the OPWC loan. The City will pay 100 percent of the annual debt service requirements and the City of Cleveland will reimburse the City 65 percent of the annual debt service requirement. The City has recorded an intergovernmental receivable in the amount of \$633,534 to recognize the City of Cleveland's share of the loan.

During 2010, the Ohio Public Works Commission (OPWC) approved a loan to the City to finance a portion of the Smith/Hummel Sewer Improvement Project Phase II. OPWC has committed up to \$573,140 at a zero percent interest rate for twenty years. The City has completed the project but only utilized \$118,139 of total \$573,140 in loan proceeds from OPWC.

During 2011, the City issued \$1,705,000 in various purpose improvement bonds, series 2011 with interest rates ranging from 2.00 percent to 3.40 percent over the life of the bonds. The proceeds from these bonds were used to finance the reconstruction of Heatherwood Drive (\$905,000) and a waterline replacement on Sheldon Road (\$800,000). The bonds will mature in 2026.

City of Brook Park, Ohio

Notes to the Basic Financial Statements (continued)

For The Year Ended December 31, 2019

Note 8: Long-Term Obligations (continued)

On October 1, 2013, the City issued \$5,520,000 in various purpose improvement bonds, series 2013 with interest rates ranging from 2.00 percent to 4.75 percent over the life of the bonds. The proceeds from these bonds were used to finance the Engle Road resurfacing project (\$1,835,000), the Engle Road sanitary sewer replacement project (\$1,965,000), and the Smith Road sanitary sewer project (\$1,720,000). The bonds will be fully matured in 2033.

During 2015, the Ohio Public Works Commission (OPWC) approved a loan to the City of Berea to finance the Eastland Road Reconstruction Project. OPWC has committed up to \$1,900,900 at a zero percent interest rate for twenty years. The City, the City of Berea and the City of Middleburg Heights have an agreement to share the debt service requirements of the OPWC loan. The City of Berea will pay 100 percent of the annual debt service requirements; the City will reimburse the City of Berea 34 percent of the annual debt service requirement; the City of Middleburg Heights will reimburse the City of Berea 43 percent of the annual debt service requirement.

During 2017, the Ohio Public Works Commission (OPWC) finalized a loan to the City to finance a portion of the Smith Rd. Sanitary Sewer Improvement Project Phase III. OPWC has committed up to \$802,825 at a zero percent interest rate for twenty years.

During 2019, the Ohio Public Works Commission (OPWC) finalized a loan to the City to finance a portion of the Holland Road Reconstruction has committed up to \$494,400 at a zero percent interest rate for twenty years. The project is still outstanding and final amortization schedules are not yet provided. The total amount disbursed on the loan as of December 31, 2019 is \$106,689.

On April 26, 2017 the City issued \$4,980,000 in Energy Conservation Improvement bonds with interest rates ranging from 1.00 percent to 4.00 percent over the life of the bonds. The proceeds from these bonds were used to finance the Community Center Project. The bonds will be fully matured in 2037.

Compensated absences are generally paid from the General Fund, Street Maintenance Special Revenue Fund, State Highway Special Revenue Fund, and Community Diversion Special Revenue Fund.

See Note 9 for additional information on capital leases. There is no repayment schedule for the Net Pension/OPEB Liability; however, employer pension and OPEB contributions are made from the General Fund, SCMR, Police Pension, and Fire Pension funds. The City's overall legal debt margin was \$37,463,484 at December 31, 2019.

This space is intentionally left blank

City of Brook Park, Ohio

Notes to the Basic Financial Statements (continued)

For The Year Ended December 31, 2019

Note 8: Long-Term Obligations (continued)

Principal and interest requirements to retire long-term obligations outstanding at December 31, 2019 are as follows:

Year	General Obligation Bonds		OPWC Loans	Total
	Principal	Interest	Principal	
2020	590,000	361,563	87,915	1,039,478
2021	620,000	344,793	175,830	1,140,623
2022	645,000	324,413	175,831	1,145,244
2023	670,000	303,233	175,829	1,149,062
2024	700,000	280,902	175,829	1,156,731
2025-2029	3,095,000	1,032,008	879,147	5,006,155
2030-2034	2,630,000	456,925	474,518	3,561,443
2035-2039	805,000	47,825	136,581	989,406
Total	<u>\$ 9,755,000</u>	<u>\$ 3,151,662</u>	<u>\$ 2,281,480</u>	<u>\$ 15,188,142</u>

Note 9: Capital Leases

The City has entered into lease agreements as lessee for financing which relate to various equipment and vehicles. These lease agreements qualify as capital leases for accounting purposes and therefore, have been recorded at the present value of their future minimum lease payments as of inception date.

	Governmental Activities
Assets:	
Vehicles	\$ 1,254,352
Less: accumulated depreciation	(190,587)
Total	<u>\$ 1,063,765</u>

The future minimum lease obligations and the net present value of these minimum lease payments as of December 31, 2019, were as follows:

Year	Payments
2020	\$ 142,827
2021	142,827
2022	142,827
Therein After	142,827
Total Minimum Lease Payments	<u>571,308</u>
Less: Amount Representing Interest	(30,743)
Present Value of Minimum Lease Payment	<u>\$ 540,565</u>

City of Brook Park, Ohio

Notes to the Basic Financial Statements (continued)

For The Year Ended December 31, 2019

Note 10: Compensated Absences

Vacation leave is earned at rates which vary depending upon length of service and standard work week. Current policy credits vacation leave on the employee's anniversary date and allows the unused balance to be carried ninety days past the subsequent anniversary date. City employees are paid for earned and unused vacation leave at the time of termination of employment.

Sick leave is earned at the rate of four and six-tenths hours for every eighty hours worked for base employees, thirteen hours for firefighters, and ten hours for police patrol. Each employee with the City is paid for four eighths of the employee's earned unused sick leave upon retirement from the City, or the full balance may be transferred to another governmental agency.

Note 11: Defined Benefit Pension Plans

A. Net Pension Liability/Asset

The net pension liability/(asset) reported on the statement of net position represents a liability to employees for pensions. Pensions are a component of exchange transactions—between an employer and its employees—of salaries and benefits for employee services. Pensions are provided to an employee—on a deferred-payment basis—as part of the total compensation package offered by an employer for employee services each financial period. The obligation to sacrifice resources for pensions is a present obligation because it was created as a result of employment exchanges that already have occurred.

The net pension liability/asset represents the City's proportionate share of each pension plan's collective actuarial present value of projected benefit payments attributable to past periods of service, net of each pension plan's fiduciary net position. The net pension liability/asset calculation is dependent on critical long-term variables, including estimated average life expectancies, earnings on investments, cost of living adjustments and others. While these estimates use the best information available, unknowable future events require adjusting this estimate annually.

Ohio Revised Code limits the City's obligation for this liability to annually required payments. The City cannot control benefit terms or the manner in which pensions are financed; however, the City does receive the benefit of employees' services in exchange for compensation including pension.

GASB 68 assumes the liability is solely the obligation of the employer, because (1) they benefit from employee services; and (2) State statute requires all funding to come from these employers. All contributions to date have come solely from these employers (which also includes costs paid in the form of withholdings from employees). State statute requires the pension plans to amortize unfunded liabilities within 30 years. If the amortization period exceeds 30 years, each pension plan's board must propose corrective action to the State legislature. Any resulting legislative change to benefits or funding could significantly affect the net pension liability. Resulting adjustments to the net pension liability would be effective when the changes are legally enforceable.

The proportionate share of each plan's unfunded benefits is presented as a long-term *net pension liability* on the accrual basis of accounting. Any liability for the contractually-required pension contribution outstanding at the end of the year is included in *intergovernmental payable* on both the accrual and modified accrual bases of accounting.

City of Brook Park, Ohio

Notes to the Basic Financial Statements (continued)

For The Year Ended December 31, 2019

Note 11: Defined Benefit Pension Plans (continued)

B. Plan Description – Ohio Public Employees Retirement System (OPERS)

Plan Description - City employees participate in the Ohio Public Employees Retirement System (OPERS). OPERS administers three separate pension plans. The traditional pension plan is a cost-sharing, multiple-employer defined benefit pension plan. The member-directed plan is a defined contribution plan and the combined plan is a cost-sharing, multiple-employer defined benefit pension plan with defined contribution features. While members (e.g. City employees) may elect the member-directed plan and the combined plan, substantially all employee members are in OPERS' traditional plan; therefore, the following disclosure focuses on the traditional pension plan.

OPERS provides retirement, disability, survivor and death benefits, and annual cost of living adjustments to members of the traditional plan. City to establish and amend benefits is provided by Chapter 145 of the Ohio Revised Code. OPERS issues a stand-alone financial report that includes financial statements, required supplementary information and detailed information about OPERS' fiduciary net position that may be obtained by visiting <https://www.opers.org/financial/reports.shtml>, by writing to the Ohio Public Employees Retirement System, 277 East Town Street, Columbus, Ohio 43215-4642, or by calling 800-222-7377.

Senate Bill (SB) 343 was enacted into law with an effective date of January 7, 2013. In the legislation, members were categorized into three groups with varying provisions of the law applicable to each group. The following table provides age and service requirements for retirement and the retirement formula applied to final average salary (FAS) for the three member groups under the traditional plan as per the reduced benefits adopted by SB 343 (see OPERS' CAFR referenced above for additional information):

Group A	Group B	Group C
Eligible to retire prior to January 7, 2013 or five years after January 7, 2013	20 years of service credit prior to January 7, 2013 or eligible to retire ten years after January 7, 2013	Members not in other Groups and members hired on or after January 7, 2013
State and Local	State and Local	State and Local
Age and Service Requirements: Age 60 with 60 months of service credit or Age 55 with 25 years of service credit	Age and Service Requirements: Age 60 with 60 months of service credit or Age 55 with 25 years of service credit	Age and Service Requirements: Age 62 with 60 months of service credit or Age 57 with 25 years of service credit
Formula: 2.2% of FAS multiplied by years of service for the first 30 years and 2.5% for service years in excess of 30	Formula: 2.2% of FAS multiplied by years of service for the first 30 years and 2.5% for service years in excess of 30	Formula: 2.2% of FAS multiplied by years of service for the first 35 years and 2.5% for service years in excess of 35

Final average Salary (FAS) represents the average of the three highest years of earnings over a member's career for Groups A and B. Group C is based on the average of the five highest years of earnings over a member's career.

City of Brook Park, Ohio

Notes to the Basic Financial Statements (continued)

For The Year Ended December 31, 2019

Note 11: Defined Benefit Pension Plans (continued)

B. Plan Description – Ohio Public Employees Retirement System (OPERS) (continued)

Members who retire before meeting the age and years of service credit requirement for unreduced benefits receive a percentage reduction in the benefit amount. The base amount of a member's pension benefit is locked in upon receipt of the initial benefit payment for calculation of the annual cost-of-living adjustment.

When a traditional plan benefit recipient has received benefits for 12 months, an annual cost of living adjustment (COLA) is provided. This COLA is calculated on the base retirement benefit at the date of retirement and is not compounded. For those retiring prior to January 7, 2013, the COLA will continue to be a 3 percent simple annual COLA. For those retiring subsequent to January 7, 2013, beginning in calendar year 2019, the COLA will be based on the average percentage increase in the Consumer Price Index, capped at 3 percent.

Defined contribution plan benefits are established in the plan documents, which may be amended by the Board. Member-directed plan and combined plan members who have met the retirement eligibility requirements may apply for retirement benefits. The amount available for defined contribution benefits in the combined plan consists of the members' contributions plus or minus the investment gains or losses resulting from the members' investment selections. Combined plan members wishing to receive benefits must meet the requirements for both the defined benefit and defined contribution plans. Member-directed participants must have attained the age of 55, have money on deposit in the defined contribution plan and have terminated public service to apply for retirement benefits. The amount available for defined contribution benefits in the member-directed plan consists of the members' contributions, vested employer contributions and investment gains or losses resulting from the members' investment selections. Employer contributions and associated investment earnings vest over a five-year period, at a rate of 20 percent each year. At retirement, members may select one of several distribution options for payment of the vested balance in their individual OPERS accounts. Options include the purchase of a monthly defined benefit annuity from OPERS (which includes joint and survivor options), partial lump-sum payments (subject to limitations), a rollover of the vested account balance to another financial institution, receipt of entire account balance, net of taxes withheld, or a combination of these options.

This space is intentionally left blank

City of Brook Park, Ohio

Notes to the Basic Financial Statements (continued)

For The Year Ended December 31, 2019

Note 11: Defined Benefit Pension Plans (continued)

B. Plan Description – Ohio Public Employees Retirement System (OPERS) (continued)

Funding Policy - The Ohio Revised Code (ORC) provides statutory City for member and employer contributions as follows:

	State and Local
2019 Statutory Maximum Contribution Rates	
Employer	14.0 %
Employee*	10.0 %
2019 Actual Contribution Rates	
Employer:	
Pension**	14.0 %
Post-Employment Health Care Benefits**	0.0
Total Employer	14.0 %
Employee	10.0 %

* Member contributions within combined plan are not used to fund the defined benefit benefit retirement allowance.

** These pension and employer health care rates are for the traditional and combined plans. The employer contributions rate for the member-directed plan is allocated 4 percent for health care with remainder going to pension.

Employer contribution rates are actuarially determined and are expressed as a percentage of covered payroll. The City’s contractually required contributions was \$763,969 for fiscal year ending December 31, 2019. Of this amount, \$17,322 is reported as an intergovernmental payable.

C. Plan Description – Ohio Police & Fire Pension Fund (OP&F)

Plan Description - City full-time police and firefighters participate in Ohio Police and Fire Pension Fund (OP&F), a cost-sharing, multiple-employer defined benefit pension plan administered by OP&F. OP&F provides retirement and disability pension benefits, annual cost-of-living adjustments, and death benefits to plan members and beneficiaries. Benefit provisions are established by the Ohio State Legislature and are codified in Chapter 742 of the Ohio Revised Code. OP&F issues a publicly available financial report that includes financial information and required supplementary information and detailed information about OP&F fiduciary net position. The report may be obtained by visiting the OP&F website at www.op-f.org or by writing to the Ohio Police and Fire Pension Fund, 140 East Town Street, Columbus, Ohio 43215-5164.

Upon attaining a qualifying age with sufficient years of service, a member of OP&F may retire and receive a lifetime monthly pension. OP&F offers four types of service retirement: normal, service commuted, age/service commuted and actuarially reduced. Each type has different eligibility guidelines and is calculated using the member’s average annual salary. The following discussion of the pension formula relates to normal service retirement.

City of Brook Park, Ohio

Notes to the Basic Financial Statements (continued)

For The Year Ended December 31, 2019

Note 11: Defined Benefit Pension Plans (continued)

C. Plan Description – Ohio Police & Fire Pension Fund (OP&F) (continued)

For members hired after July 1, 2013, the minimum retirement age is 52 for normal service retirement with at least 25 years of service credit. For members hired on or before July 1, 2013, the minimum retirement age is 48 for normal service retirement with at least 25 years of service credit.

The annual pension benefit for normal service retirement is equal to a percentage of the allowable average annual salary. The percentage equals 2.5 percent for each of the first 20 years of service credit, 2.0 percent for each of the next five years of service credit and 1.5 percent for each year of service credit in excess of 25 years. The maximum pension of 72 percent of the allowable average annual salary is paid after 33 years of service credit. Under normal service retirement, retired members who are at least 55 years old and have been receiving OP&F benefits for at least one year may be eligible for a cost-of-living allowance adjustment. The age 55 provision for receiving a COLA does not apply to those who are receiving a permanent and total disability benefit and statutory survivors. Members participating in the DROP program have separate eligibility requirements related to COLA.

Members retiring under normal service retirement, with less than 15 years of service credit on July 1, 2013, and members whose pension benefit became effective on or after July 1, 2013, will receive a COLA equal to a percentage of the members’ base pension benefit where the percentage is the lesser of three percent or the percentage increase in the consumer price index, if any, over the 12 month period that ends on the thirtieth day of September of the immediately preceding year, rounded to the nearest one-tenth of one percent.

Funding Policy - The Ohio Revised Code (ORC) provides statutory authority for member and employer contributions as follows:

	<u>Police</u>	<u>Firefighters</u>
2019 Statutory Maximum Contribution Rates		
Employer	19.50 %	24.00 %
Employee	12.25 %	12.25 %
2019 Actual Contribution Rates		
Employer:		
Pension	19.00 %	23.50 %
Post-employment Health Care Benefits	0.50	0.50
Total Employer	<u>19.50 %</u>	<u>24.00 %</u>
Employee	12.25 %	12.25 %

Employer contribution rates are expressed as a percentage of covered payroll. The City’s contractually required contribution to OP&F was \$1,388,767 for 2019. Of this amount, \$34,170 is reported as an intergovernmental payable.

City of Brook Park, Ohio

Notes to the Basic Financial Statements (continued)

For The Year Ended December 31, 2019

Note 11: Defined Benefit Pension Plans (continued)

D. Pension Liabilities, Pension Assets, Pension Expense, and Deferred Outflows of Resources and Deferred Inflows of Resources Related to Pensions

The net pension liability/asset for OPERS was measured as of December 31, 2018, and the total pension liability/asset used to calculate the net pension liability/asset was determined by an actuarial valuation as of that date. OP&F's total pension liability was measured as of December 31, 2018, and was determined by rolling forward the total pension liability as of January 1, 2018, to December 31, 2018. The City's proportion of the net pension liability/asset was based on the City's share of contributions to the pension plan relative to the contributions of all participating entities. Following is information related to the proportionate share and pension expense:

	OPERS Traditional Pension Plan	OPERS Combined Pension Plan	OP&F Police	OP&F Fire	Total
Proportion of the Net Pension Liability/Asset Prior Measurement Date	0.0407830%	0.019061%	0.1339190%	0.1494950%	
Proportion of the Net Pension Liability/Asset Current Measurement Date	<u>0.0393600%</u>	<u>0.019224%</u>	<u>0.1333900%</u>	<u>0.1506090%</u>	
Change in Proportionate Share	<u>-0.0014230%</u>	<u>0.000163%</u>	<u>-0.000529%</u>	<u>0.001114%</u>	
Proportionate Share of the Net Pension Liability/(Asset)	\$ 10,779,906	\$ (21,497)	\$ 10,888,149	\$ 12,293,674	\$ 33,940,232
Pension Expense	\$ 2,268,993	\$ 6,299	\$ 1,373,037	\$ 1,649,167	\$ 5,297,496

This space is intentionally left blank

City of Brook Park, Ohio

Notes to the Basic Financial Statements (continued)

For The Year Ended December 31, 2019

Note 11: Defined Benefit Pension Plans (continued)

D. Pension Liabilities, Pension Assets, Pension Expense, and Deferred Outflows of Resources and Deferred Inflows of Resources Related to Pensions (Continued)

At December 31, 2019, the City reported deferred outflows of resources and deferred inflows of resources related to pensions from the following sources:

	OPERS Traditional	OPERS Combined	OP&F Police	OP&F Fire	Total
Deferred Outflows of Resources					
Net difference between projected and actual earnings on pension plan investments	\$ 1,463,135	\$ 4,632	\$ 1,341,409	\$ 1,514,571	\$ 4,323,747
Differences between expected and actual experience	496	-	447,350	505,100	952,946
Changes of assumptions	938,413	4,800	288,660	325,923	1,557,796
Changes in proportion and differences between City contributions and proportionate share of contributions	4,801	2,705	230,140	391,225	628,871
City contributions subsequent to the measurement date	752,088	11,881	647,096	741,671	2,152,736
Total Deferred Outflows of Resources	\$ 3,158,933	\$ 24,018	\$ 2,954,655	\$ 3,478,490	\$ 9,616,096
Deferred Inflows of Resources					
Differences between expected and actual experience	\$ 141,546	\$ 8,779	\$ 10,166	\$ 11,480	\$ 171,971
Changes in proportion and differences between City contributions and proportionate share of contributions	201,507	547	320,277	201,887	724,218
Total Deferred Inflows of Resources	\$ 343,053	\$ 9,326	\$ 330,443	\$ 213,367	\$ 896,189

\$2,152,736 reported as deferred outflows of resources related to pension resulting from City's contributions subsequent to the measurement date will be recognized as a reduction of the net pension liability in the year ending December 31, 2020. Other amounts reported as deferred outflows of resources and deferred inflows of resources related to pension will be recognized in pension expense as follows:

	OPERS Traditional	OPERS Combined	OP&F Police	OP&F Fire	Total
Year Ending December 31:					
2020	\$ 853,096	\$ 1,059	\$568,300	\$740,545	\$ 2,163,000
2021	394,496	136	274,974	409,358	1,078,964
2022	135,736	233	429,611	546,784	1,112,364
2023	680,464	1,680	657,072	769,346	2,108,562
2024	-	(218)	47,159	57,419	104,360
Thereafter	-	(79)	-	-	(79)
Total	\$2,063,792	\$2,811	\$1,977,116	\$2,523,452	\$6,567,171

City of Brook Park, Ohio

Notes to the Basic Financial Statements (continued)

For The Year Ended December 31, 2019

Note 11: Defined Benefit Pension Plans (continued)

E. Actuarial Assumptions - OPERS

Actuarial valuations of an ongoing plan involve estimates of the values of reported amounts and assumptions about the probability of occurrence of events far into the future. Examples include assumptions about future employment, mortality, and cost trends. Actuarially determined amounts are subject to continual review or modification as actual results are compared with past expectations and new estimates are made about the future.

Projections of benefits for financial reporting purposes are based on the substantive plan (the plan as understood by the employers and plan members) and include the types of benefits provided at the time of each valuation. The total pension liability in the December 31, 2018, actuarial valuation was determined using the following actuarial assumptions, applied to all prior periods included in the measurement in accordance with the requirements of GASB 67. Key methods and assumptions used in the latest actuarial valuation, reflecting experience study results, are presented below:

Wage Inflation	3.25 percent
Future Salary Increases, including inflation COLA or Ad Hoc COLA	3.25 to 10.75 percent including wage inflation Pre 1/7/2013 retirees; 3 percent, simple Post 1/7/2013 retirees; 3 percent, simple through 2018, then 2.15 percent simple
Investment Rate of Return	7.2 percent
Actuarial Cost Method	Individual Entry Age

The total pension asset in the December 31, 2018, actuarial valuation was determined using the following actuarial assumptions, applied to all periods included in the measurement:

Wage Inflation	3.25 percent
Future Salary Increases, including inflation COLA or Ad Hoc COLA	3.25 to 8.25 percent including wage inflation Pre 1/7/2013 retirees; 3 percent, simple Post 1/7/2013 retirees; 3 percent, simple through 2018, then 2.15 percent simple
Investment Rate of Return	7.2 percent
Actuarial Cost Method	Individual Entry Age

Pre-retirement mortality rates are based on the RP-2014 Employees mortality table for males and females, adjusted for mortality improvement back to the observation period base year of 2006. The base year for males and females was then established to be 2015 and 2010, respectively. Post-retirement mortality rates are based on the RP-2014 Healthy Annuitant mortality table for males and females, adjusted for mortality improvement back to the observation period base year of 2006. The base year for males and females was then established to be 2015 and 2010, respectively. Post-retirement mortality rates for disabled retirees are based on the RP-2014 Disabled mortality table for males and females, adjusted for mortality improvement back to the observation period base year of 2006. The base year for males and females was then established to be 2015 and 2010, respectively. Mortality rates for a particular calendar year are determined by applying the MP-2015 mortality improvement scale to all of the previously described tables.

City of Brook Park, Ohio

Notes to the Basic Financial Statements (continued)

For The Year Ended December 31, 2019

Note 11: Defined Benefit Pension Plans (continued)

E. Actuarial Assumptions – OPERS (continued)

The most recent experience study was completed for the five-year period ended December 31, 2015.

The long-term rate of return on defined benefit investment assets was determined using a building-block method in which best-estimate ranges of expected future real rates of return are developed for each major asset class. These ranges are combined to produce the long-term expected real rate of return by weighting the expected future real rates of return by the target asset allocation percentage, adjusted for inflation.

OPERS manages investments in three investment portfolios: the Defined Benefits portfolio, the Health Care portfolio, and the Defined Contribution portfolio. The Defined Benefit portfolio includes the investment assets of the Traditional Pension Plan, the defined benefit component of the Combined Plan, the annuitized accounts of the Member-Directed Plan. Within the Defined Benefit portfolio, contributions into the plans are all recorded at the same time, and benefit payments all occur on the first of the month. Accordingly, the money-weighted rate of return is considered to be the same for all plans within the portfolio. The annual money weighted rate of return expressing investment performance, net of investments expenses and adjusted for the changing amounts actually invested, for the Defined Benefit portfolio is 16.82 percent for 2017 and 2.94 percent for 2018.

The allocation of investment assets with the Defined Benefit portfolio is approved by the Board of Trustees as outlined in the annual investment plan. Plan assets are managed on a total return basis with a long-term objective of achieving and maintaining a fully funded status for the benefits provided through the defined benefit pension plans. The table on the following page displays the Board-approved asset allocation policy for 2018 and the long-term expected real rates of return:

Asset Class	Target Allocation	Weighted Average Long-Term Expected Real Rate of Return (Arithmetic)
Fixed Income	23.00 %	2.79 %
Domestic Equities	19.00	6.21
Real Estate	10.00	4.90
Private Equity	10.00	10.81
International Equities	20.00	7.83
Other investments	18.00	5.50
Total	100.00 %	5.95 %

Discount Rate The discount rate used to measure the total pension liability was 7.2 percent, post-experience study results. The projection of cash flows used to determine the discount rate assumed that contributions from plan members and those of the contributing employers are made at the contractually required rates, as actuarially determined. Based on those assumptions, the pension plan's fiduciary net position was projected to be available to make all projected future benefits payments of current plan members. Therefore, the long-term expected rate of return on pension plan investments was applied to all periods of projected benefit payments to determine the total pension liability.

City of Brook Park, Ohio

Notes to the Basic Financial Statements (continued)

For The Year Ended December 31, 2019

Note 11: Defined Benefit Pension Plans (continued)

E. Actuarial Assumptions – OPERS (continued)

Sensitivity of the City’s Proportionate Share of the Net Pension Liability to Changes in the Discount Rate

The following table presents the City’s proportionate share of the net pension liability calculated using the current period discount rate assumption of 7.2 percent, as well as what the City’s proportionate share of the net pension liability would be if it were calculated using a discount rate that is one-percentage-point lower (6.2 percent) or one-percentage-point higher (8.2 percent) than the current rate:

City's proportionate share of the net pension liability/(asset)	1% Decrease (6.20%)	Current Discount Rate (7.20%)	1% Increase (8.20%)
Traditional Pension Plan	\$15,925,056	\$ 10,779,906	\$6,504,240
Combined Plan	(\$7,113)	\$ (21,497)	(\$31,912)

F. Actuarial Assumptions – OP&F

OP&F’s total pension liability as of December 31, 2018 is based on the results of an actuarial valuation date of January 1, 2018, and rolled-forward using generally accepted actuarial procedures. The total pension liability is determined by OP&F’s actuaries in accordance with GASB Statement No. 67, as part of their annual valuation. Actuarial valuations of an ongoing plan involve estimates of reported amounts and assumptions about probability of occurrence of events far into the future. Examples include assumptions about future employment mortality, salary increases, disabilities, retirements and employment terminations. Actuarially determined amounts are subject to continual review and potential modifications, as actual results are compared with past expectations and new estimates are made about the future. Assumptions considered were: withdrawal rates, disability retirement, service retirement, DROP elections, mortality, percent married and forms of the payment, DROP interest rate, CPI-based COLA, investment returns, salary increases and payroll growth.

Key methods and assumptions used in calculating the total pension liability in the latest actuarial valuation, prepared as of January 1, 2018, are presented below:

Valuation Date	January 1, 2018, with actuarial liabilities rolled forward to December 31, 2018
Actuarial Cost Method	Entry Age Normal
Investment Rate of Return	8.00 percent
Projected Salary Increases	3.75 percent to 10.5 percent
Payroll Growth	Inflation rate of 2.75 percent plus productivity increase rate of 0.5 percent
Cost of Living Adjustments	3.00 percent simple, 2.2 percent simple for increases based on the lesser of the increase in CPI and 3 percent

City of Brook Park, Ohio

Notes to the Basic Financial Statements (continued)

For The Year Ended December 31, 2019

Note 11: Defined Benefit Pension Plans (continued)

F. Actuarial Assumptions – OP&F (continued)

Mortality for non-disabled participants is based on the RP-2014 Total Employee and Healthy Annuitant Mortality Tables rolled back to 2006, adjusted according to the rates in the following table, and projected with the Conduent Modified 2016 Improvement Scale. Rates for surviving beneficiaries are adjusted by 120 percent.

<u>Age</u>	<u>Police</u>	<u>Fire</u>
67 or less	77 %	68 %
68-77	105	87
78 and up	115	120

Mortality for disabled retirees is based on the RP-2014 Disabled Mortality Tables rolled back to 2006, adjusted according to the rates in the following table, and projected with the Conduent Modified 2016 Improvement Scale. Mortality rates for active members were based on the RP2014 Total employee and Healthy Annuitant Mortality Tables rolled back to 2006, and projected with the Conduent Modified 2016 Improvement Scale.

<u>Age</u>	<u>Police</u>	<u>Fire</u>
59 or less	35 %	35 %
60-69	60	45
70-79	75	70
80 and up	100	90

The most recent experience study was completed January 1, 2017.

The long-term expected rate of return on pension plan investments was determined using a building-block approach and assumes a time horizon, as defined in the Statement of Investment Policy. A forecasted rate of inflation serves as the baseline for the return expectation. Various real return premiums over the baseline inflation rate have been established for each asset class. The long-term expected nominal rate of return has been determined by calculating a weighted averaged of the expected real return premiums for each asset class, adding the projected inflation rate and adding the expected return from rebalancing uncorrelated asset classes. Best estimates of the long-term expected geometric real rates of return for each major asset class included in OP&F's target asset allocation as of December 31, 2018 are summarized on the following page:

City of Brook Park, Ohio

Notes to the Basic Financial Statements (continued)

For The Year Ended December 31, 2019

Note 11: Defined Benefit Pension Plans (continued)

F. Actuarial Assumptions – OP&F (continued)

Asset Class	Target Allocation	10 year Expected Real Rate of Return **	30 year Expected Real Rate of Return **
Cash and Cash Equivalents	0.00 %	1.00 %	0.80 %
Domestic Equity	16.00	5.60	5.50
Non-US Equity	16.00	6.10	5.90
Core Fixed Income *	23.00	2.20	2.60
U.S. Inflation Linked Bonds *	17.00	1.30	2.30
High Yield Fixed Income	7.00	4.20	4.80
Real Estate	12.00	5.70	6.10
Private Markets	8.00	8.40	8.40
Master Limited Partnerships	8.00	6.70	6.40
Private Credit	5.00	8.30	7.50
Real Assets	8.00	7.00	7.00
Total	120.00 %		

Note: Assumptions are geometric

* levered 2x

** numbers are net of expected inflation

OP&F's Board of Trustees has incorporated the "risk parity" concept into OP&F's asset liability valuation with the goal of reducing equity risk exposure, which reduces overall Total Portfolio risk without sacrificing return, and creating a more risk-balanced portfolio based on their relationship between asset classes and economic environments. From the notional portfolio perspective above, the Total Portfolio may be levered up to 1.2 times due to the application of leverage in certain fixed income asset classes.

Discount Rate The total pension liability was calculated using the discount rate of 8.00 percent. The projection of cash flows used to determine the discount rate assumed the contributions from employers and from the members would be computed based on contribution requirements as stipulated by State statute. Projected inflows from investment earning were calculated using the longer-term assumed investment rate of return 8.00 percent. Based on those assumptions, the plan's fiduciary net position was projected to be available to make all future benefit payments of current plan members. Therefore, a long-term expected rate of return on pension plan investments was applied to all periods of projected benefits to determine the total pension liability.

Sensitivity of the City's Proportionate Share of the Net Pension Liability to Changes in the Discount Rate

Net pension liability is sensitive to changes in the discount rate, and to illustrate the potential impact the following table presents the net pension liability calculated using the discount rate of 8.00 percent, as well as what the net pension liability would be if it were calculated using a discount rate that is one percentage point lower (7.00 percent), or one percentage point higher (9.00 percent) than the current rate.

	1% Decrease (7.00%)	Current Discount Rate (8.00%)	1% Increase (9.00%)
City's proportionate share of the net pension liability	\$ 30,470,908	\$ 23,181,823	\$ 17,090,739

City of Brook Park, Ohio

Notes to the Basic Financial Statements (continued)

For The Year Ended December 31, 2019

Note 12: Defined Benefit Multiple-Employer OPEB Plan

A. Net OPEB Liability

The net OPEB liability reported on the statement of net position represents a liability to employees for OPEB. OPEB is a component of exchange transactions—between an employer and its employees—of salaries and benefits for employee services. OPEB are provided to an employee—on a deferred-payment basis—as part of the total compensation package offered by an employer for employee services each financial period. The obligation to sacrifice resources for OPEB is a present obligation because it was created as a result of employment exchanges that already have occurred.

The net OPEB liability represents the City's proportionate share of each OPEB plan's collective actuarial present value of projected benefit payments attributable to past periods of service, net of each OPEB plan's fiduciary net position. The net OPEB liability calculation is dependent on critical long-term variables, including estimated average life expectancies, earnings on investments, cost of living adjustments and others. While these estimates use the best information available, unknowable future events require adjusting these estimates annually.

Ohio Revised Code limits the City's obligation for this liability to annually required payments. The City cannot control benefit terms or the manner in which OPEB are financed; however, the City does receive the benefit of employees' services in exchange for compensation including OPEB.

GASB 75 assumes the liability is solely the obligation of the employer, because they benefit from employee services. OPEB contributions come from these employers and health care plan enrollees which pay a portion of the health care costs in the form of a monthly premium. The Ohio revised Code permits, but does not require the retirement systems to provide healthcare to eligible benefit recipients. Any change to benefits or funding could significantly affect the net OPEB liability. Resulting adjustments to the net OPEB liability would be effective when the changes are legally enforceable. The retirement systems may allocate a portion of the employer contributions to provide for these OPEB benefits.

The proportionate share of each plan's unfunded benefits is presented as a long-term *net OPEB liability* on the accrual basis of accounting. Any liability for the contractually-required OPEB contribution outstanding at the end of the year is included in *intergovernmental payable* on both the accrual and modified accrual bases of accounting.

B. Plan Description – Ohio Public Employees Retirement System (OPERS)

Plan Description - The Ohio Public Employees Retirement System (OPERS) administers three separate pension plans: the traditional pension plan, a cost-sharing, multiple-employer defined benefit pension plan; the member-directed plan, a defined contribution plan; and the combined plan, a cost-sharing, multiple-employer defined benefit pension plan that has elements of both a defined benefit and defined contribution plan.

City of Brook Park, Ohio

Notes to the Basic Financial Statements (continued)

For The Year Ended December 31, 2019

Note 12: Defined Benefit Multiple Employer OPEB Plan (continued)

B. Plan Description – Ohio Public Employees Retirement System (OPERS) (continued)

OPERS maintains a cost-sharing, multiple-employer defined benefit post-employment health care trust, which funds multiple health care plans including medical coverage, prescription drug coverage and deposits to a Health Reimbursement Arrangement to qualifying benefit recipients of both the traditional pension and the combined plans. This trust is also used to fund health care for member-directed plan participants, in the form of a Retiree Medical Account (RMA). At retirement or refund, member directed plan participants may be eligible for reimbursement of qualified medical expenses from their vested RMA balance.

In order to qualify for postemployment health care coverage, age and service retirees under the traditional pension and combined plans must have twenty or more years of qualifying Ohio service credit. Health care coverage for disability benefit recipients and qualified survivor benefit recipients is available. The health care coverage provided by OPERS meets the definition of an Other Post Employment Benefit (OPEB) as described in GASB Statement 75. See OPERS' CAFR referenced below for additional information.

The Ohio Revised Code permits, but does not require OPERS to provide health care to its eligible benefit recipients. Authority to establish and amend health care coverage is provided to the Board in Chapter 145 of the Ohio Revised Code.

Disclosures for the health care plan are presented separately in the OPERS financial report. Interested parties may obtain a copy by visiting <https://www.opers.org/financial/reports.shtml>, by writing to OPERS, 277 East Town Street, Columbus, Ohio 43215-4642, or by calling (614) 222-5601 or 800-222-7377.

Funding Policy - The Ohio Revised Code provides the statutory authority requiring public employers to fund postemployment health care through their contributions to OPERS. When funding is approved by OPERS Board of Trustees, a portion of each employer's contribution to OPERS is set aside to fund OPERS health care plans. During 2019 health care is not being funded.

Employer contribution rates are expressed as a percentage of the earnable salary of active members. In 2019, state and local employers contributed at a rate of 14.0 percent of earnable salary and public safety and law enforcement employers contributed at 18.1 percent. These are the maximum employer contribution rates permitted by the Ohio Revised Code. Active member contributions do not fund health care.

Each year, the OPERS Board determines the portion of the employer contribution rate that will be set aside to fund health care plans. The portion of employer contributions allocated to health care for members in the Traditional Pension Plan and Combined Plan was 0 percent during calendar year 2018. The OPERS Board is also authorized to establish rules for the retiree or their surviving beneficiaries to pay a portion of the health care provided. Payment amounts vary depending on the number of covered dependents and the coverage selected. The employer contribution as a percentage of covered payroll deposited into the RMA for participants in the Member-Directed Plan for 2019 was 4.0 percent.

Employer contribution rates are actuarially determined and are expressed as a percentage of covered payroll. The City's contractually required contribution was \$20 for 2019.

City of Brook Park, Ohio

Notes to the Basic Financial Statements (continued)

For The Year Ended December 31, 2019

Note 12: Defined Benefit Multiple Employer OPEB Plan (continued)

C. Plan Description – Ohio Police & Fire Pension Fund (OP&F)

Plan Description – The City contributes to the Ohio Police and Fire Pension Fund (OP&F) sponsored healthcare program, a cost-sharing, multiple-employer defined post-employment healthcare plan administered by a third-party provider. This program is not guaranteed and is subject to change at any time upon action of the Board of Trustees. OP&F provides health care benefits including coverage for medical, prescription drug, dental, vision, and Medicare Part B Premium to retirees, qualifying benefit recipients and their eligible dependents.

OP&F provides access to postretirement health care coverage for any person who receives or is eligible to receive a monthly service, disability, or statutory survivor benefit, or is a spouse or eligible dependent child of such person. The health care coverage provided by OP&F meets the definition of an Other Post Employment Benefit (OPEB) as described in Government Accounting Standards Board (GASB) Statement No. 75.

The Ohio Revised Code allows, but does not mandate, OP&F to provide OPEB benefits. Authority for the OP&F Board of Trustees to provide health care coverage to eligible participants and to establish and amend benefits is codified in Chapter 742 of the Ohio Revised Code.

OP&F issues a publicly available financial report that includes financial information and required supplementary information for the plan. The report may be obtained by visiting the OP&F website at www.op-f.org or by writing to the Ohio Police and Fire Pension Fund, 140 East Town Street, Columbus, Ohio 43215-5164.

Funding Policy – The Ohio Revised Code provides for contribution requirements of the participating employers and of plan members to the OP&F defined benefit pension plan. Participating employers are required to contribute to the pension plan at rates expressed as percentages of the payroll of active pension plan members, currently 19.5 percent and 24 percent of covered payroll for police and fire employer units, respectively. The Ohio Revised Code states that the employer contribution may not exceed 19.5 percent of covered payroll for police employer units and 24 percent of covered payroll for fire employer units. Active members do not make contributions to the OPEB Plan.

OP&F maintains funds for health care in two separate accounts. There is one account for health care benefits and one account for Medicare Part B reimbursements. A separate health care trust accrual account is maintained for health care benefits under IRS Code Section 115 trust. An Internal Revenue Code 401(h) account is maintained for Medicare Part B reimbursements.

The Board of Trustees is authorized to allocate a portion of the total employer contributions made into the pension plan to the Section 115 trust and the Section 401(h) account as the employer contribution for retiree health care benefits. For 2019, the portion of employer contributions allocated to health care was 0.5 percent of covered payroll. The amount of employer contributions allocated to the health care plan each year is subject to the Trustees' primary responsibility to ensure that pension benefits are adequately funded and is limited by the provisions of Sections 115 and 401(h).

The OP&F Board of Trustees is also authorized to establish requirements for contributions to the health care plan by retirees and their eligible dependents or surviving beneficiaries. Payment amounts vary depending on the number of covered dependents and the coverage selected.

City of Brook Park, Ohio

Notes to the Basic Financial Statements (continued)

For The Year Ended December 31, 2019

Note 12: Defined Benefit Multiple Employer OPEB Plan (continued)

C. Plan Description – Ohio Police & Fire Pension Fund (OP&F) (continued)

On January 1, 2019, OP&F changed its retiree health care model and the current self-insured health care plan will no longer be offered. In its place is a stipend-based health care model. A stipend funded by OP&F will be placed in individual Health Reimbursement Accounts that retirees will use to be reimbursed for health care expenses.

The City's contractually required contribution to OP&F was \$32,809 for 2019.

D. OPEB Liabilities, OPEB Expense, and Deferred Outflows of Resources and Deferred Inflows of Resources Related to OPEB

The net OPEB liability and total OPEB liability for OPERS were determined by an actuarial valuation as of December 31, 2017, rolled forward to the measurement date of December 31, 2018, by incorporating the expected value of health care cost accruals, the actual health care payment, and interest accruals during the year. OP&F's total OPEB liability was measured as of December 31, 2018, and was determined by rolling forward the total OPEB liability as of January 1, 2018, to December 31, 2018. The City's proportion of the net OPEB liability was based on the City's share of contributions to the retirement plan relative to the contributions of all participating entities. Following is information related to the proportionate share and OPEB expense:

	<u>OPERS</u>	<u>OP&F</u>	<u>Total</u>
Proportion of the Net OPEB Liability			
Prior Measurement Date	0.038630%	0.283414%	
Proportion of the Net OPEB Liability			
Current Measurement Date	<u>0.037289%</u>	<u>0.284000%</u>	
Change in Proportionate Share	<u>-0.001341%</u>	<u>0.000586%</u>	
Proportionate Share of the Net OPEB			
Liability	\$ 4,861,605	\$ 2,586,253	\$ 7,447,858
OPEB Expense	\$ 371,039	\$ (12,650,989)	\$ (12,279,950)

City of Brook Park, Ohio

Notes to the Basic Financial Statements (continued)

For The Year Ended December 31, 2019

Note 12: Defined Benefit Multiple Employer OPEB Plan (continued)

D. OPEB Liabilities, OPEB Expense, and Deferred Outflows of Resources and Deferred Inflows of Resources Related to OPEB (Continued)

At December 31, 2019, the City reported deferred outflows of resources and deferred inflows of resources related to OPEB from the following sources:

	<u>OPERS</u>	<u>OP&F</u>	<u>Total</u>
Deferred Outflows of Resources			
Net difference between projected and actual earnings on OPEB plan investments	\$ 222,877	\$ 87,548	\$ 310,425
Differences between expected and actual experience	1,647	-	1,647
Changes of assumptions	156,745	1,340,589	1,497,334
Changes in proportion and differences between City contributions and proportionate share of contributions	-	476,128	476,128
City contributions subsequent to the measurement date	<u>20</u>	<u>32,809</u>	<u>32,829</u>
Total Deferred Outflows of Resources	<u><u>381,289</u></u>	<u><u>1,937,074</u></u>	<u><u>2,318,363</u></u>
Deferred Inflows of Resources			
Differences between expected and actual experience	13,191	69,291	82,482
Changes of assumptions	-	715,997	715,997
Changes in proportion and differences between City contributions and proportionate share of contributions	<u>133,167</u>	<u>-</u>	<u>133,167</u>
Total Deferred Inflows of Resources	<u><u>\$146,358</u></u>	<u><u>\$ 785,288</u></u>	<u><u>\$931,646</u></u>

\$32,829 reported as deferred outflows of resources related to OPEB resulting from City contributions subsequent to the measurement date will be recognized as a reduction of the net OPEB liability in 2020. Other amounts reported as deferred outflows of resources and deferred inflows of resources related to OPEB will be recognized in OPEB expense on the following page:

Year Ending December 31:	<u>OPERS</u>	<u>OP&F</u>	<u>Total</u>
2020	\$ 95,993	\$ 196,170	\$ 292,163
2021	(8,522)	196,170	187,648
2022	35,163	196,172	231,335
2023	112,277	222,652	334,929
2024	-	180,904	180,904
Thereafter	<u>-</u>	<u>126,909</u>	<u>126,909</u>
Total	<u><u>\$ 234,911</u></u>	<u><u>\$ 1,118,977</u></u>	<u><u>\$ 1,353,888</u></u>

City of Brook Park, Ohio

Notes to the Basic Financial Statements (continued)

For The Year Ended December 31, 2019

Note 12: Defined Benefit Multiple Employer OPEB Plan (continued)

E. Actuarial Assumptions - OPERS

Actuarial valuations of an ongoing plan involve estimates of the values of reported amounts and assumptions about the probability of occurrence of events far into the future. Examples include assumptions about future employment, mortality, and cost trends. Actuarially determined amounts are subject to continual review or modification as actual results are compared with past expectations and new estimates are made about the future.

Projections of benefits for financial reporting purposes are based on the substantive plan and include the types of coverage provided at the time of each valuation and the historical pattern of sharing of costs between OPERS and plan members. The total OPEB liability was determined by an actuarial valuation as of December 31, 2017, rolled forward to the measurement date of December 31, 2018. The actuarial valuation used the following actuarial assumptions applied to all prior periods included in the measurement in accordance with the requirements of GASB 74:

Wage Inflation	3.25 percent
Projected Salary Increases, including inflation	3.25 to 10.75 percent including wage inflation
Single Discount Rate:	
Current measurement date	3.96 percent
Prior Measurement date	3.85 percent
Investment Rate of Return	6.00 percent
Municipal Bond Rate	3.71 percent
Health Care Cost Trend Rate	10.0 percent, initial 3.25 percent, ultimate in 2029
Actuarial Cost Method	Individual Entry Age

Pre-retirement mortality rates are based on the RP-2014 Employees mortality table for males and females, adjusted for mortality improvement back to the observation period base year of 2006. The base year for males and females was then established to be 2015 and 2010, respectively. Post-retirement mortality rates are based on the RP-2014 Healthy Annuitant mortality table for males and females, adjusted for mortality improvement back to the observation period base year of 2006. The base year for males and females was then established to be 2015 and 2010, respectively. Post-retirement mortality rates for disabled retirees are based on the RP-2014 Disabled mortality table for males and females, adjusted for mortality improvement back to the observation period base year of 2006. The base year for males and females was then established to be 2015 and 2010, respectively. Mortality rates for a particular calendar year are determined by applying the MP-2015 mortality improvement scale to all of the above described tables.

The most recent experience study was completed for the five-year period ended December 31, 2015.

The long-term expected rate of return on health care investment assets was determined using a building-block method in which best-estimate ranges of expected future real rates of return are developed for each major asset class. These ranges are combined to produce the long-term expected real rate of return by weighting the expected future real rates of return by the target asset allocation percentage, adjusted for inflation.

City of Brook Park, Ohio

Notes to the Basic Financial Statements (continued)

For The Year Ended December 31, 2019

Note 12: Defined Benefit Multiple Employer OPEB Plan (continued)

E. Actuarial Assumptions – OPERS (continued)

OPERS managed investments in three investment portfolios: the Defined Benefit portfolio, the Health Care portfolio and the Defined Contribution portfolio. The Health Care portfolio includes the assets for health care expenses for the Traditional Pension Plan, Combined Plan and Member-Directed Plan eligible members. Within the Health Care portfolio, contributions into the plans are assumed to be received continuously throughout the year based on the actual payroll payable at the time contributions are made, and health care-related payments are assumed to occur mid-year. Accordingly, the money-weighted rate of return is considered to be the same for all plans within the portfolio. The annual money-weighted rate of return expressing investment performance, net of investment expenses and adjusted for the changing amounts actually invested, for the Health Care portfolio is 5.60 percent for 2018.

The allocation of investment assets with the Health Care portfolio is approved by the Board of Trustees as outlined in the annual investment plan. Assets are managed on a total return basis with a long-term objective of continuing to offer a sustainable health care program for current and future retirees. OPERS' primary goal is to achieve and maintain a fully funded status for the benefits provided through the defined pension plans. Health care is a discretionary benefit. The table below displays the Board-approved asset allocation policy for 2018 and the long-term expected real rates of return:

<u>Asset Class</u>	<u>Target Allocation</u>	<u>Weighted Average Long-Term Expected Real Rate of Return (Arithmetic)</u>
Fixed Income	34.00 %	2.42 %
Domestic Equities	21.00	6.21
Real Estate Investment Trust	6.00	5.98
International Equities	22.00	7.83
Other investments	17.00	5.57
Total	<u>100.00 %</u>	5.16 %

Discount Rate A single discount rate of 3.96 percent was used to measure the OPEB liability on the measurement date of December 31, 2018. A single discount rate of 3.85 percent was used to measure the OPEB liability on the measurement date of December 31, 2017. Projected benefit payments are required to be discounted to their actuarial present value using a single discount rate that reflects (1) a long-term expected rate of return on OPEB plan investments (to the extent that the health care fiduciary net position is projected to be sufficient to pay benefits), and (2) tax-exempt municipal bond rate based on an index of 20-year general obligation bonds with an average AA credit rating as of the measurement date (to the extent that the contributions for use with the long-term expected rate are not met). This single discount rate was based on an expected rate of return on the health care investment portfolio of 6.00 percent and a municipal bond rate of 3.71 percent. The projection of cash flows used to determine this single discount rate assumed that employer contributions will be made at rates equal to the actuarially determined contribution rate. Based on these assumptions, the health care fiduciary net position and future contributions were sufficient to finance health care costs through 2031. As a result, the long-term expected rate of return on health care investments was applied to projected costs through the year 2031, and the municipal bond rate was applied to all health care costs after that date.

City of Brook Park, Ohio

Notes to the Basic Financial Statements (continued)

For The Year Ended December 31, 2019

Note 12: Defined Benefit Multiple Employer OPEB Plan (continued)

E. Actuarial Assumptions – OPERS (continued)

Sensitivity of the City’s Proportionate Share of the Net OPEB Liability to Changes in the Discount Rate

The following table presents the City’s proportionate share of the net OPEB liability calculated using the single discount rate of 3.96 percent, as well as what the City’s proportionate share of the net OPEB liability would be if it were calculated using a discount rate that is one-percentage-point lower (2.96 percent) or one-percentage-point higher (4.96 percent) than the current rate:

	1% Decrease (2.96%)	Current Discount Rate (3.96%)	1% Increase (4.96%)
City's proportionate share of the net OPEB liability	\$6,219,805	\$4,861,605	\$3,781,477

Sensitivity of the City’s Proportionate Share of the Net OPEB Liability to Changes in the Health Care Cost Trend Rate

Changes in the health care cost trend rate may also have a significant impact on the net OPEB liability. The following table presents the net OPEB liability calculated using the assumed trend rates, and the expected net OPEB liability if it were calculated using a health care cost trend rate that is 1.0 percent lower or 1.0 percent higher than the current rate.

Retiree health care valuations use a health care cost-trend assumption that changes over several years built into the assumption. The near-term rates reflect increases in the current cost of health care; the trend starting in 2019 is 10.00 percent. If this trend continues for future years, the projection indicates that years from now virtually all expenditures will be for health care. A more reasonable alternative is that in the not-too-distant future, the health plan cost trend will decrease to a level at, or near, wage inflation. On this basis, the actuaries project premium rate increases will continue to exceed wage inflation for approximately the next decade, but by less each year, until leveling off at an ultimate rate, assumed to be 3.25 percent in the most recent valuation.

	1% Decrease	Current Health Care Cost Trend Rate Assumption	1% Increase
City's proportionate share of the net OPEB liability	\$4,673,057	\$4,861,605	\$5,078,762

F. Actuarial Assumptions – OP&F

OP&F’s total OPEB liability as of December 31, 2018, is based on the results of an actuarial valuation date of January 1, 2018, and rolled-forward using generally accepted actuarial procedures. The total OPEB liability is determined by OP&F’s actuaries in accordance with GASB Statement No. 74, as part of their annual valuation. Actuarial valuations of an ongoing plan involve estimates of reported amounts and assumptions about probability of occurrence of events far into the future. Examples include assumptions about future employment mortality, salary increases, disabilities, retirements and employment terminations. Actuarially determined amounts are subject to continual review and potential modifications, as actual results are compared with past expectations and new estimates are made about the future.

City of Brook Park, Ohio

Notes to the Basic Financial Statements (continued)

For The Year Ended December 31, 2019

Note 12: Defined Benefit Multiple Employer OPEB Plan (continued)

F. Actuarial Assumptions – OP&F (continued)

Projections of benefits for financial reporting purposes are based on the substantive plan (the plan as understood by the employers and plan members) and include the types of benefits provided at the time of each valuation and the historical pattern of sharing benefit costs between the employers and plan members to that point. The projection of benefits for financial reporting purposes does not explicitly incorporate the potential effects of legal or contractual funding limitations.

Actuarial calculations reflect a long-term perspective. For a newly hired employee, actuarial calculations will take into account the employee’s entire career with the employer and also take into consideration the benefits, if any, paid to the employee after termination of employment until the death of the employee and any applicable contingent annuitant. In many cases, actuarial calculations reflect several decades of service with the employer and the payment of benefits after termination.

Key methods and assumptions used in the latest actuarial valuation, reflecting experience study results, are presented below.

Valuation Date	January 1, 2018, with actuarial liabilities rolled forward to December 31, 2018
Actuarial Cost Method	Entry Age Normal
Investment Rate of Return	8.0 percent
Projected Salary Increases	3.75 percent to 10.5 percent
Payroll Growth	Inflation rate of 2.75 percent plus productivity increase rate of 0.5 percent
Single discount rate:	
Current measurement date	4.66 percent
Prior measurement date	3.24 percent
Cost of Living Adjustments	3.00 percent simple; 2.2 percent simple for increased based on the lesser of the increase in CPI and 3 percent

Mortality for non-disabled participants is based on the RP-2014 Total Employee and Healthy Annuitant Mortality Tables rolled back to 2006, adjusted according to the rates in the following table, and projected with the Conduent Modified 2016 Improvement Scale. Rates for surviving beneficiaries are adjusted by 120 percent.

Age	Police	Fire
67 or less	77 %	68 %
68-77	105	87
78 and up	115	120

City of Brook Park, Ohio

Notes to the Basic Financial Statements (continued)

For The Year Ended December 31, 2019

Note 12: Defined Benefit Multiple Employer OPEB Plan (continued)

F. Actuarial Assumptions – OP&F (continued)

Mortality for disabled retirees is based on the RP-2014 Disabled Mortality Tables rolled back to 2006, adjusted according to the rates in the following table, and projected with the Conduent Modified 2016 Improvement Scale.

Age	Police	Fire
59 or less	35 %	35 %
60-69	60	45
70-79	75	70
80 and up	100	90

The most recent experience study was completed for the five-year period ended January 1, 2017.

The long-term expected rate of return on OPEB plan investments was determined using a building-block approach and assumes a time horizon, as defined in the Statement of Investment Policy. A forecasted rate of inflation serves as the baseline for the return expected. Various real return premiums over the baseline inflation rate have been established for each asset class. The long-term expected nominal rate of return has been determined by calculating a weighted averaged of the expected real return premiums for each asset class, adding the projected inflation rate and adding the expected return from rebalancing uncorrelated asset classes. Best estimates of the long-term expected geometric real rates of return for each major asset class included in OP&F's target asset allocation as of December 31, 2018, are summarized as follows:

Asset Class	Target Allocation	10 year Expected Real Rate of Return **	30 year Expected Real Rate of Return **
Cash and Cash Equivalents	0.00 %	1.00 %	0.80 %
Domestic Equity	16.00	5.30	5.50
Non-US Equity	16.00	6.10	5.90
Core Fixed Income *	23.00	2.20	2.60
U.S. Inflation Linked Bonds *	17.00	1.30	2.30
High Yield Fixed Income	7.00	4.20	4.80
Real Estate	12.00	5.70	6.10
Private Markets	8.00	8.40	8.40
Master Limited Partnerships	8.00	6.70	6.40
Private Credit	5.00	8.30	7.50
Real Assets	8.00	7.00	7.00
Total	<u>120.00 %</u>		

Note: Assumptions are geometric

* levered 2x

** numbers are net of expected inflation

City of Brook Park, Ohio

Notes to the Basic Financial Statements (continued)

For The Year Ended December 31, 2019

Note 12: Defined Benefit Multiple Employer OPEB Plan (continued)

F. Actuarial Assumptions – OP&F (continued)

OP&F's Board of Trustees has incorporated the risk parity concept into OP&F's asset liability valuation with the goal of reducing equity risk exposure, which reduces overall Total Portfolio risk without sacrificing return, and creating a more risk-balanced portfolio based on the relationship between asset classes and economic environments. From the notional portfolio perspective above, the Total Portfolio may be levered up to 1.2 times due to the application of leverage in certain fixed income asset classes.

Discount Rate The total OPEB liability was calculated using the discount rate of 4.66 percent. The projection of cash flows used to determine the discount rate assumed the contribution from employers and from members would be computed based on contribution requirements as stipulated by state statute. Projected inflows from investment earnings were calculated using the longer-term assumed investment rate of return 8 percent. Based on those assumptions, OP&F's fiduciary net position was projected to not be able to make all future benefit payments of current plan members. Therefore, a municipal bond rate of 4.13 percent at December 31, 2018 and 3.16 percent at December 31, 2017, was blended with the long-term rate of 8 percent, which resulted in a blended discount rate of 4.66 percent. The municipal bond rate was determined using the S&P Municipal Bond 20 Year High Grade Rate Index. The OPEB plan's fiduciary net position was projected to be available to make all projected OPEB payments until 2025. The long-term expected rate of return on health care investments was applied to projected costs through 2025, and the municipal bond rate was applied to all health care costs after that date.

Sensitivity of the City's Proportionate Share of the Net OPEB Liability to Changes in the Discount Rate

Net OPEB liability is sensitive to changes in the discount rate, and to illustrate the potential impact the following table presents the net OPEB liability calculated using the discount rate of 4.66 percent, as well as what the net OPEB liability would be if it were calculated using a discount rate that is one percentage point lower (3.66 percent), or one percentage point higher (5.66 percent) than the current rate.

	1% Decrease (2.24%)	Current Discount Rate (3.24%)	1% Increase (4.24%)
City's proportionate share of the net OPEB liability	\$3,150,762	\$2,586,253	\$2,112,396

Sensitivity of the City's Proportionate Share of the Net OPEB Liability to Changes in the Health Care Cost

Trend Rate Net OPEB liability is sensitive to changes in the health care cost trend rate because it is based on a medical benefit that is a flat dollar amount.

Changes between Measurement Date and Report Date

Beginning January 1, 2019 OP&F is changing its retiree health care model and the current self-insured health care plan will no longer be offered. In its place will be a stipend-based health care model. OP&F has contracted with a vendor who will assist eligible retirees in choosing health care plans from their marketplace (both Medicare-eligible and pre-Medicare populations). A stipend funded by OP&F will be placed in individual Health Reimbursement Accounts that retirees will use to be reimbursed for health care expenses. As a result of changing from the current health care model to the stipend-based health care model, management expects that it will be able to provide stipends to eligible participants for the next 15 years.

City of Brook Park, Ohio

Notes to the Basic Financial Statements (continued)

For The Year Ended December 31, 2019

Note 13: Defined Benefit Single Employer OPEB Plan

A. Net OPEB Liability

The net OPEB liability reported on the statement of net position represents a liability to employees for OPEB. OPEB is a component of exchange transactions—between an employer and its employees—of salaries and benefits for employee services. OPEB are provided to an employee—on a deferred-payment basis—as part of the total compensation package offered by an employer for employee services each financial period. The obligation to sacrifice resources for OPEB is a present obligation because it was created as a result of employment exchanges that already have occurred.

The net OPEB liability represents the actuarial present value of projected benefit payments attributable to past periods of service. The net OPEB liability calculation is dependent on critical long-term variables, including estimated average life expectancies, earnings on investments, cost of living adjustments and others. While these estimates use the best information available, unknowable future events require adjusting these estimates annually.

The City has control over the benefit terms through Council approved ordinances and is financed through the City's General Fund; however, the City received the benefits of retiree's services for the required number of years and the retirees have reached the eligible age that requires the City to provide this OPEB.

GASB 75 assumes the liability is solely the obligation of the employer, because they benefit from employee services. OPEB contributions comes solely and directly from the City for enrollee's health care reimbursements and life insurance premiums are paid directly to the insurer on behalf of the cover retiree. Any change to benefits or funding could significantly affect the net OPEB liability. Resulting adjustments to the net OPEB liability would be effective when the changes are legally enforceable.

B. Plan Description

The City provides post-employment health care and life insurance benefits (OPEB) for retired employees through a single-employer defined benefit plan. The benefits, benefit levels, employee contributions and employer contributions are governed by the City and can be amended by the City through council-approved ordinance. The activity of the plan is reported in the City's General Fund as part of the general government expenditure function.

C. Benefits Provided

The City provides post-employment health care and life insurance benefits (OPEB) to its retirees. In order to be eligible for the benefit, a retired employee or surviving spouse must be at least age 65 plus 10 consecutive years of service prior to retirement. In addition, a retired employee/surviving spouse must be enrolled in Medicare Part B to be eligible for the benefit.

Post-employment benefits include reimbursement of costs associated with health care coverage up to \$1,200 per year and a life insurance of \$5,000 which the City provides the premium payment. Dependents of eligible retirees will continue to receive the post-employment benefits at the time of the retiree's death.

City of Brook Park, Ohio

Notes to the Basic Financial Statements (continued)

For The Year Ended December 31, 2019

Note 13: Defined Benefit Single Employer OPEB Plan (continued)

C. *Benefits Provided (continued)*

As of January 1, 2017, the City had 274 participants (most recent information available). Of that number, 136 were active employees and 138 were retirees and dependents that were currently receiving the post-employment mentioned on the previous page. The valuation excluded 61 retirees from the liability as they did not receive any benefits in 2016 or 2017. It is assumed that they will not be rejoining the plan in the future.

D. *Funding Policy*

The City's annual contributions to the plan are approved by council through ordinance 10064-2016. The City's contractually required contributions were \$93,076 for 2019. The plan does not require matching contributions from employees during their period of employment.

E. *OPEB Liabilities, OPEB Expense, and Deferred Outflows of Resources and Deferred Inflows of Resources Related to OPEB*

The net OPEB liability and total OPEB liability was determined by an actuarial valuation as of January 1, 2018, rolled forward to the measurement date of December 31, 2018, by incorporating the expected value of the OPEB's cost accruals, the actual payment, and interest accruals during the year. The City's net OPEB liability was based on the aforementioned actuarial valuation. Following is information related to the Net OPEB Liability and OPEB expense:

Proportionate Share of the Net OPEB Liability	\$	1,678,466
OPEB Expense	\$	105,731

At December 31, 2019, the City reported deferred outflows of resources and deferred inflows of resources related to OPEB from the following sources:

	<u>OPERS</u>
Deferred Outflows of Resources	
Differences between expected and actual experience	\$ 38,048
City contributions subsequent to the measurement date	<u>93,076</u>
Total Deferred Outflows of Resources	<u>\$ 131,124</u>
Deferred Inflows of Resources	
Differences between expected and actual experience	<u>\$ 157,189</u>
Total Deferred Inflows of Resources	<u>\$ 157,189</u>

\$93,076 reported as deferred outflows of resources related to OPEB resulting from City contributions subsequent to the measurement date will be recognized as a reduction of the net OPEB liability in 2020.

City of Brook Park, Ohio

Notes to the Basic Financial Statements (continued)

For The Year Ended December 31, 2019

Note 13: Defined Benefit Single Employer OPEB Plan (continued)

E. OPEB Liabilities, OPEB Expense, and Deferred Outflows of Resources and Deferred Inflows of Resources Related to OPEB (continued)

Other amounts reported as deferred outflows of resources and deferred inflows of resources related to OPEB will be recognized in OPEB expense as follows:

Year Ending December 31:	<u>OPERS</u>
2020	\$ (9,294)
2021	(9,294)
2022	(9,294)
2023	(9,294)
2024	(9,294)
Thereafter	<u>(72,671)</u>
Total	<u>\$ (119,141)</u>

F. Actuarial Assumptions

Actuarial valuations of an ongoing plan involve estimates of the value of reported amounts and assumptions about the probability of occurrence of events far into the future. Examples include assumptions about future employment, mortality, and the healthcare cost trend. Amounts determined regarding the funded status of the plan and the ARC's of the employer are subject to continual revision as actual results are compared with past expectations and new estimates are made about the future.

Projections of benefits for financial reporting purposes are based on the substantive plan and include the types of coverage provided at the time of each valuation and the historical pattern of sharing of costs between the OPEB and plan members. The actuarial valuation used the following actuarial assumptions applied to all prior periods included in the measurement in accordance with the requirements of GASB 74:

Annual Wage Increases	3.50 percent
Single Discount Rate:	3.20 Percent
Investment Rate of Return	3.20 percent
Municipal Bond Rate	3.20 percent
Actuarial Value of Assets	Market Value
Funding Policy	Pay-as-you-go
Actuarial Cost Method	Entry Age Normal
Annual Per-Capita Claims Cost	\$1,200 - for 2017 and beyond
Medical	Medicare Part B Reimbursement

Annual Per-Capita Claims Cost	Year	Cost/\$1,000	Coverage	Total Premium
Life Insurance*	2017	0.245	\$ 5,000	\$ 14.70
	2018	0.341	5,000	20.46

City of Brook Park, Ohio

Notes to the Basic Financial Statements (continued)

For The Year Ended December 31, 2019

Note 13: Defined Benefit Single Employer OPEB Plan (continued)

Mortality for participants is based on the SOA RP-2014 Blue Collar Mortality with Scale MP-2017. No disabilities are assumed for the active population. For retirees currently disabled, no recovery from disability is assumed.

For future police and fire retirees, participation assumes that 90% of future retirees will elect to receive Medicare Part B Supplement and the reimbursement. 100% of future retirees will elect for life insurance.

For future City retirees, participation assumes that 90% of future retirees will elect to receive Medicare Part B Supplement and the reimbursement. 100% of future retirees will elect for life insurance.

For current retirees, the actual elections as reported are used. It is assumed current retirees will continue coverage until death. Spouses are assumed to be 3 years younger than the member.

G. Discount Rate

The total OPEB liability was calculated using the discount rate of 3.20 percent. Since the plan is funded by a “pay-as-you-go” system, the 20-year AA rated municipal bond rate was used as both the discount and investment rate of return. The municipal bond rate was determined through www.fmsbonds.com/market-yields/ on May 3, 2018.

This space is intentionally left blank

City of Brook Park, Ohio

Notes to the Basic Financial Statements (continued)

For The Year Ended December 31, 2019

Note 13: Defined Benefit Single Employer OPEB Plan (continued)

H. *Changes in the Net OPEB Liability*

The following tables represent the changes in the Net OPEB Liability during the measurement period based on actuarial valuation date of January 1, 2018:

<u>Reconciliation of Total OPEB Liability</u>	
1/1/18 Net OPEB Liability	\$1,835,770
Service Cost	42,939
Interest Cost	58,701
Contributions	(89,329)
New Inflow - experience	<u>(169,615)</u>
12/31/18 Net OPEB Liability	<u><u>\$1,678,466</u></u>

<u>Reconciliation of Fiduciary Net Position</u>	
1/1/18 Fiduciary Net Position	\$ -
Employer Contributions	(89,329)
Total Benefits paid	<u>89,329</u>
12/31/18 Fiduciary Net Position	<u><u>\$ -</u></u>

<u>Net OPEB Liability</u>	
Total OPEB Liability	\$1,678,466
Fiduciary Net Position	<u>-</u>
Net OPEB Liability	<u><u>\$1,678,466</u></u>

Due to the plan using the pay-as-you-go method, there will be no Fiduciary Net Position.

Note 14: Risk Management

The City is exposed to various risks of loss related to torts; theft of, damage to, and destruction of assets; errors and omissions; injuries to employees and natural disasters. During the year, the City contracted with Wichert Insurance Services, Inc. to manage its insurance coverage. The City's insurance carrier for all coverages is Selective Insurance Co. of America. The coverage limits, on December 31, 2019, per occurrence for all types of coverage are as follows:

City of Brook Park, Ohio

Notes to the Basic Financial Statements (continued)

For The Year Ended December 31, 2019

Note 14: Risk Management (Continued)

<u>Type of Coverage</u>	<u>Coverage</u>
Property:	
Blanket building and contents	\$ 49,652,571
Business income and extra expense	Actual Loss Sustained-12 mos.
General liability:	
Commercial general liability, which includes:	2,000,000
Employee benefits	1,000,000
Employers liability (Ohio stop gap)	1,000,000
Automotive liability	1,000,000
Excess liability:	
Umbrella, which includes:	10,000,000
All underlying liabilities	
Public officials and law enforcement	
Other types of coverages:	
Contractors equipment	1,190,325
EDP equipment	346,585
Employee dishonesty	1,000,000
Valuable papers	100,000
Accounts receivable	100,000
Law enforcement	1,000,000
Public Officials	1,000,000
Flood	Each Occurrence 5,000,000 Aggregate 10,000,000
Earthquake	Each Occurrence 5,000,000 Aggregate 10,000,000

There were no reductions in insurance coverage from the previous year, nor have settlements exceeded insurance coverage in any of the prior three fiscal years.

During 2017, the City switched from self-funded program for health insurance to a shared-funding plan provided by a commercial insurance carrier. The City will pay up to a predetermined amount towards each employee's health care costs after employee's health care costs after employees meet their deductible. Once this "funding corridor" has been met, the insurance company will pay the employee's remaining annual health care costs.

All pending claims activity is reported in Internal Service Fund, which will be closed out subsequently. The Internal Service fund is still being maintained until City is certain that all prior claims have been paid out as there is uncertainty as to exactly when claims will be processed. As of December 31, 2019, there are no known claims payable to the City for the past two years.

The State of Ohio provides workers' compensation coverage. The City pays the State Workers' Compensation System a premium based on a rate per \$100 of salaries. This rate is calculated based on accident history and administrative costs.

City of Brook Park, Ohio

Notes to the Basic Financial Statements (continued)

For The Year Ended December 31, 2019

Note 15: Construction and Other Significant Commitments

At December 31, 2019, the City’s significant contractual construction commitments consisted of:

Project	Amount	Paid	on Contract
Holland Rd Reconstruction	\$ 2,277,245	\$ 1,984,009	\$ 293,236
Total	\$ 2,277,245	\$ 1,984,009	\$ 293,236

The City utilizes encumbrance accounting as part of its budgetary controls. Encumbrances outstanding at year-end are components of fund balance for subsequent year expenditures and may be reported as part of restricted, committed, or assigned classifications of fund balance. As of December 31, 2019, the City’s commitments for encumbrances in the governmental funds were as follows:

	Encumbrances Outstanding
Major Funds:	
General	\$ 191,397
Capital Improvements	1,579,553
Nonmajor Funds:	
Special Revenue Funds	517,604
Total	\$ 2,288,554

Note 16: Interfund Transfers

Interfund transfers for the year ended December 31, 2019, consisted of the following:

Transfer To	Transfer From			Total
	General Fund	Capital Improvements Fund	Nonmajor Governmental Funds	
General Fund	\$ -	\$ 450,986	\$ 112,602	\$ 563,588
Capital Improvements Fund	1,050,000	-	-	1,050,000
Other Governmental Funds	1,630,688	780,047	-	2,410,735
Total	\$ 2,680,688	\$ 1,231,033	\$ 112,602	\$ 4,024,323

Transfers are used to move revenues from the fund that statute or budget requires to collect them to the fund that statute or budget requires to expend them and unrestricted revenues collected in the general fund to finance various programs accounted for in other funds in accordance with budgetary authorizations; to segregate money for anticipated capital projects; to provide additional resources for current operations or debt service; and to return money to the fund from which it was originally provided once a project is completed.

City of Brook Park, Ohio

Notes to the Basic Financial Statements (continued)

For The Year Ended December 31, 2019

Note 17: Contingencies/Pending Litigation

A. Grants

The City received financial assistance from Federal and State agencies in the form of grants. The disbursement of funds received under these programs generally requires compliance with the terms and conditions specified in the grant agreements and are subject to audit by the grantor agencies. Any disallowed claims resulting from such audits could become a liability of the General Fund or other applicable funds. However, in the opinion of management, any such disallowed claims will not have a material adverse effect on the overall financial position of the City at December 31, 2019.

B. Litigation

There are claims and lawsuits that are pending against the City. The amount of the liability from these claims and lawsuits, if any, cannot be reasonably estimated at this time. However, in the opinion of management, any such claims and lawsuits will not have a material adverse effect on the overall financial position of the City at December 31, 2019.

This page intentionally left blank

City of Brook Park, Ohio

Notes to the Basic Financial Statements (continued)

For The Year Ended December 31, 2019

Note 18: Fund Balances

Fund balance is classified as nonspendable, restricted, committed, assigned and/or unassigned based primarily on the extent to which the City is bound to observe constraints imposed upon the use of the resources in the governmental funds. The constraints placed on fund balance for the major governmental funds and all other governmental funds are presented below:

Fund Balances	General Fund	Capital Improvements Fund	Other Governmental Funds	Total
<i>Nonspendable</i>				
Prepaid Items	\$ 408,510	\$ -	\$ -	\$ 408,510
Materials and Supplies Inventory	193,237	-	-	193,237
<i>Total Nonspendable</i>	<u>601,747</u>	<u>-</u>	<u>-</u>	<u>601,747</u>
<i>Restricted for</i>				
Police Pension	-	-	16,893	16,893
Fire Pension	-	-	19,947	19,947
Other Law Enforcement	-	-	403,242	403,242
Streets and Highways	-	-	2,086,462	2,086,462
FEMA	-	-	54,663	54,663
CDBG	-	-	36,290	36,290
Debt Service	-	-	661,977	661,977
Capital Improvements	-	214,400	-	214,400
Snow Rd. Resurfacing	-	13,203	-	13,203
<i>Total Restricted</i>	<u>-</u>	<u>227,603</u>	<u>3,279,474</u>	<u>3,507,077</u>
<i>Committed to</i>				
Income Tax Allocation - Capital	-	1,189,908	-	1,189,908
Admissions Tax	845,206	-	-	845,206
Hotel and Motel Tax	827,840	-	-	827,840
Property Insurance	1,194,969	-	-	1,194,969
Retiree Accrued Benefits	122,995	-	-	122,995
Economic Development	-	-	990,214	990,214
Brook Park Road Corridor	-	-	57,835	57,835
Special Recreation	-	-	472,071	472,071
Ditch Cleaning Program	-	222,869	-	222,869
Sound Insulation Program	-	181,499	-	181,499
Street Programs	-	1,349,936	-	1,349,936
<i>Total Committed</i>	<u>2,991,010</u>	<u>2,944,212</u>	<u>1,520,120</u>	<u>7,455,342</u>
<i>Assigned to</i>				
Fiscal Year 2020 Appropriations	2,125,080	-	-	2,125,080
Park Concessions	8,040	-	-	8,040
Debt Service	-	-	1,309,936	1,309,936
Safety Forces	64,337	-	-	64,337
Public Health	38	-	-	38
Recreation	8,005	-	-	8,005
Community Development	10,513	-	-	10,513
Sanitation	39,041	-	-	39,041
Streets	5,183	-	-	5,183
General Government	56,302	-	-	56,302
Other	2,550	-	-	2,550
<i>Total Assigned</i>	<u>2,319,089</u>	<u>-</u>	<u>1,309,936</u>	<u>3,629,025</u>
<i>Unassigned</i>	<u>6,980,856</u>	<u>-</u>	<u>-</u>	<u>6,980,856</u>
Total Fund Balances	<u>\$ 12,892,702</u>	<u>\$ 3,171,815</u>	<u>\$ 6,109,530</u>	<u>\$ 22,174,047</u>

City of Brook Park, Ohio

Notes to the Basic Financial Statements (continued)

For The Year Ended December 31, 2019

Note 19: Tax Abatement Disclosure

The City of Brook Park provides tax incentive programs through Ohio Revised Code Chapter 3735.65-70 and/or Chapter 5709 (Community Re-Investment Act (CRA)) and through a payroll tax rebate program. The city established its CRA and has amended its program twice so that the entire city is covered by the CRA.

The CRA program provides the city with an important economic development tool to stimulate growth and redevelopment in its industrial, commercial and residential bases. The abate program provides a direct incentive property tax exemption for improvements to real estate within the City. Improvements to residential property (not containing more than 2 residential units) valued exceeding \$2,500 are available to receive a 10-year, 100% property tax abatement for the increase in assessed value resulting from the improvement. Remodeling in excess of \$5,000 to residential multi-family, commercial & industrial properties are eligible to receive a 12-year 100% abatement from the increase in assessed value resulting from the improvement. Likewise, construction of new commercial or industrial improvements (excluding properties primarily used in retail sales) are eligible for a 100%, fifteen (15) year abatement of real property taxes arising from the increase in assessed value resulting from the improvement. All CRA property tax abatements are reported to the State of Ohio on an annual basis.

The amount of tax abated for tax year 2018/collection year 2019 is \$16,072 at December 31, 2019

In the past the city has offered an income tax rebate (up to 50% for a defined period (up to five (5) years)) to entities with established multi-million dollar payrolls who agree to maintain established and negotiated payrolls for a defined period of years (7 years or longer). Like rebates have been offered to businesses with multi-million dollar payrolls in order to keep the business from relocating out of city due to a competitive rebate offer or to entice a business to relocate to our City by matching an income tax rebate offered by a competitive jurisdiction. No income tax rebates have been authorized by the City in the past four (4) years.

Note 20: Subsequent Event Note

The United States and the State of Ohio declared a state of emergency in March 2020 due to the COVID-19 pandemic. The financial impact of COVID-19 and the ensuing emergency measures will impact subsequent periods of the City. The impact on the City's future operating costs, revenues, and any recovery from emergency funding, either federal or state, cannot be estimated.

Required Supplementary Information

City of Brook Park, Ohio
Required Supplementary Information
Schedule of the City's Proportionate Share of the Net Pension Liability
Ohio Public Employees Retirement System
Last Six Years (1)

Traditional Plan	2019	2018	2017	2016	2015	2014
City's Proportion of the Net Pension Liability	0.039360%	0.040783%	0.041502%	0.040125%	0.048064%	0.048064%
City's Proportionate Share of the Net Pension Liability	\$10,779,906	\$6,398,062	\$9,424,398	\$6,950,154	\$5,797,055	\$5,666,119
City's Covered Payroll	\$5,314,714	\$5,388,477	\$5,364,108	\$4,993,992	\$5,912,167	\$6,018,854
City's Proportionate Share of the Net Pension Liability as a Percentage of its Covered Payroll	202.83%	118.74%	175.69%	139.17%	98.05%	94.14%
Plan Fiduciary Net Position as a Percentage of the Total Pension Liability	74.70%	84.66%	77.25%	81.08%	86.45%	86.36%
Combined Plan	2019	2018	2017	2016	2015	2014
City's Proportion of the Net Pension (Asset)	0.019224%	0.019061%	0.020787%	0.027150%	0.024994%	0.024994%
City's Proportionate Share of the Net Pension (Asset)	(\$21,497)	(\$25,948)	(\$11,569)	(\$13,212)	(\$9,623)	(\$2,623)
City's Covered Payroll	\$82,221	\$78,062	\$80,917	\$98,792	\$92,050	\$106,362
City's Proportionate Share of the Net Pension (Asset) as a Percentage of its Covered Payroll	26.15%	33.24%	14.30%	13.37%	10.45%	2.47%
Plan Fiduciary Net Position as a Percentage of the Total Pension Liability (Asset)	126.64%	137.28%	116.55%	116.90%	114.83%	104.33%

(1) Information prior to 2014 is not available. Schedule is intended to show ten years of information, and additional years' will be displayed as it becomes available.

Amounts presented as of the City's measurement date which is the prior year end.

See accompanying notes to the required supplementary information

City of Brook Park, Ohio
Requires Supplementary Information
Schedule of the City's Proportionate Share of the Net Pension Liability
Ohio Police and Fire Pension Fund
Last Six Years (1)

Police	2019	2018	2017	2016	2015	2014
City's Proportion of the Net Pension Liability	0.133390%	0.1339190%	0.1280200%	0.1288433%	0.1437298%	0.1437298%
City's Proportionate Share of the Net Pension Liability	\$10,888,149	\$8,219,214	\$8,108,677	\$8,288,580	\$7,445,803	\$7,000,092
City's Covered Payroll	\$3,332,063	\$3,262,589	\$3,076,132	\$2,916,400	\$3,354,032	\$3,061,875
City's Proportionate Share of the Net Pension Liability as a Percentage of its Covered Payroll	326.77%	251.92%	263.60%	284.21%	222.00%	228.62%
Plan Fiduciary Net Position as a Percentage of the Total Pension Liability	63.07%	70.91%	68.36%	66.77%	71.71%	73.00%
Fire	2019	2018	2017	2016	2015	2014
City's Proportion of the Net Pension Liability	0.0150609%	0.1494950%	0.1426650%	0.1403890%	0.1516112%	0.1516112%
City's Proportionate Share of the Net Pension Liability	\$12,293,674	\$9,175,183	\$9,036,258	\$9,031,323	\$7,854,092	\$7,383,941
City's Covered Payroll	\$3,083,366	\$2,977,945	\$2,786,979	\$2,569,609	\$2,812,226	\$2,830,504
City's Proportionate Share of the Net Pension Liability as a Percentage of its Covered Payroll	398.71%	308.10%	324.23%	351.47%	279.28%	260.87%
Plan Fiduciary Net Position as a Percentage of the Total Pension Liability	63.07%	70.91%	68.36%	66.77%	71.71%	73.00%

(1) Information prior to 2014 is not available. Schedule is intended to show ten years of information, and additional years' will be displayed as it becomes available.

Amounts presented as of the City's measurement date which is the prior year end.

See accompanying notes to the required supplementary information

City of Brook Park, Ohio

Required Supplementary Information

Schedule of City Contributions – Net Pension Liability

Ohio Public Employees Retirement System

Last Seven Years (1)

	<u>2019</u>	<u>2018</u>	<u>2017</u>	<u>2016</u>	<u>2015</u>	<u>2014</u>	<u>2013</u>
<u>Contractually Required Contributions</u>							
Traditional Plan	752,088	744,060	700,502	643,693	599,279	709,460	782,451
Combined Plan	11,881	11,511	10,148	9,710	11,855	11,046	13,827
Total Required Contributions	\$763,969	\$755,571	\$710,650	\$653,403	\$611,134	\$720,506	\$796,278
Contributions in Relation to the Contractually Required Contribution	(\$763,969)	(\$755,571)	(\$710,650)	(\$653,403)	(\$611,134)	(\$720,506)	(\$796,278)
Contribution Deficiency / (Excess)	\$0	\$0	\$0	\$0	\$0	\$0	\$0
<u>City's Covered Payroll</u>							
Traditional Plan	\$5,372,057	\$5,314,714	\$5,388,477	\$5,364,108	\$4,993,992	\$5,912,167	\$6,018,854
Combined Plan	\$84,864	\$82,221	\$78,062	\$80,917	\$98,792	\$92,050	\$106,362
<u>Pension Contributions as a Percentage of Covered Payroll</u>							
Traditional Plan	14.00%	14.00%	13.00%	12.00%	12.00%	12.00%	13.00%
Combined Plan	14.00%	14.00%	13.00%	12.00%	12.00%	12.00%	13.00%

(1) Information prior to 2013 is not available. Schedule is intended to show ten years of information, and additional years' will be displayed as it becomes available.

See accompanying notes to the required supplementary information

City of Brook Park, Ohio
Required Supplementary Information
Schedule of City Contributions – Net Pension Liability
Ohio Police and Fire Pension Fund
Last Ten Years

	<u>2019</u>	<u>2018</u>	<u>2017</u>	<u>2016</u>	<u>2015</u>	<u>2014</u>	<u>2013</u>	<u>2012</u>	<u>2011</u>	<u>2010</u>
<u>Contractually Required Contributions</u>										
Police	\$647,096	\$633,092	\$619,892	\$584,465	\$554,116	\$637,266	\$481,633	\$388,484	\$395,232	\$405,512
Fire	\$741,671	\$724,591	\$699,817	\$654,940	\$603,858	\$660,873	\$572,611	\$517,304	\$538,686	\$538,555
Total Required Contributions	\$1,388,767	\$1,357,683	\$1,319,709	\$1,239,405	\$1,157,974	\$1,298,139	\$1,054,244	\$905,788	\$933,918	\$944,067
Contributions in Relation to the Contractually Required Contribution	(\$1,388,767)	(\$1,357,683)	(\$1,319,709)	(\$1,239,405)	(\$1,157,974)	(\$1,298,139)	(\$1,054,244)	(\$905,788)	(\$933,918)	(\$944,067)
Contribution Deficiency / (Excess)	\$0	\$0	\$0	\$0	\$0	\$0	\$0	\$0	\$0	\$0
<u>City's Covered Payroll</u>										
Police	\$3,405,768	\$3,332,063	\$3,262,589	\$3,076,132	\$2,916,400	\$3,354,032	\$3,061,875	\$3,046,933	\$3,099,859	\$3,180,486
Fire	\$3,156,047	\$3,083,366	\$2,977,945	\$2,786,979	\$2,569,609	\$2,812,226	\$2,830,504	\$2,998,864	\$3,122,817	\$3,122,058
<u>Pension Contributions as a Percentage of Covered Payroll</u>										
Police	19.00%	19.00%	19.00%	19.00%	19.00%	19.00%	[1]	12.75%	12.75%	12.75%
Fire	23.50%	23.50%	23.50%	23.50%	23.50%	23.50%	[1]	17.25%	17.25%	17.25%

[1] – The portion of the City's contributions to fund pension obligations from January 1, 2013 thru May 31, 2013, for both police officers and firefighters was 14.81 percent and 19.31 percent, respectively. The portion of the City's contributions to fund pension obligations from June 1, 2013 thru December 31, 2013 for both police officers and firefighters was 16.65 percent and 21.15 percent, respectively.

See accompanying notes to the required supplementary information

City of Brook Park, Ohio

Required Supplementary Information

Schedule of the City's Proportionate Share of the Net OPEB Liability

Ohio Public Employees Retirement System

Last Three Years (1)

	<u>2019</u>	<u>2018</u>	<u>2017</u>
City's Proportion of the Net OPEB Liability	0.037289%	0.038630%	0.039410%
City's Proportionate Share of the Net OPEB Liability	\$ 4,861,605	\$ 4,194,933	\$ 3,980,544
City's Covered Payroll	\$ 5,407,031	\$ 5,472,234	\$ 5,446,304
City's Proportionate Share of the Net OPEB Liability as a Percentage of its Covered Payroll	89.91%	76.66%	73.09%
Plan Fiduciary Net Position as a Percentage of the Total OPEB Liability	46.33%	54.14%	54.04%

(1) Information prior to 2017 is not available. Schedule is intended to show ten years of information, and additional years' will be displayed as it becomes available.

Amounts presented as of the City's measurement date, which is the prior calendar year end.

See accompanying notes to the required supplementary information

City of Brook Park, Ohio

Required Supplementary Information

Schedule of the City's Proportionate Share of the Net OPEB Liability

Ohio Police and Fire Pension Fund

Last Three Years (1)

	2019	2018	2017
City's Proportion of the Net OPEB Liability	0.284000%	0.283414%	0.270690%
City's Proportionate Share of the Net OPEB Liability	\$ 2,586,253	\$ 16,057,841	\$ 12,849,046
City's Covered Payroll	\$ 6,415,429	\$ 6,240,534	\$ 5,863,111
City's Proportionate Share of the Net OPEB Liability as a Percentage of its Covered Payroll	40.31%	257.32%	219.15%
Plan Fiduciary Net Position as a Percentage of the Total OPEB Liability	46.57%	14.13%	15.96%

(1) Information prior to 2017 is not available. Schedule is intended to show ten years of information, and additional years' will be displayed as it becomes available.

Amounts presented as of the City's measurement date, which is the prior calendar year end.

See accompanying notes to the required supplementary information

City of Brook Park, Ohio
 Required Supplementary Information
 Schedule of the City's Net OPEB Liability
 Other Post-Employment Benefits – Single Employer
Last Three Years (1)

	<u>2019</u>	<u>2018</u>	<u>2017</u>
Total OPEB Liability	\$ 1,678,466	\$ 1,835,770	\$ 1,785,707
OPEB Plan's Fiduciary Net Position	-	-	-
Net OPEB Liability	\$ 1,678,466	\$ 1,835,770	\$ 1,785,707
City's Covered Payroll	\$ 11,812,364	\$ 11,707,073	\$ 11,308,136
City's Proportionate Share of the Net OPEB Liability as a Percentage of its Covered Payroll	14.21%	15.68%	15.79%
Plan Fiduciary Net Position as a Percentage of the Total OPEB Liability	0.00%	0.00%	0.00%

(1) Information prior to 2017 is not available. Schedule is intended to show ten years of information, and additional years' will be displayed as it becomes available.

Amounts presented as of the City's measurement date, which is the prior calendar year end.

See accompanying notes to the required supplementary information

City of Brook Park, Ohio
Required Supplementary Information
Schedule of the City's Contributions – Net OPEB Liability
Ohio Public Employees Retirement System
Last Five Years (1)

	2019	2018	2017	2016	2015
Contractually Required Contribution	\$ 20	\$ 404	\$ 54,847	\$ 108,926	\$ 101,855
Contributions in Relation to the Contractually Required Contribution	(20)	(404)	(54,847)	(108,926)	(101,855)
Contribution Deficiency (Excess)	<u>\$ -</u>	<u>\$ -</u>	<u>\$ -</u>	<u>\$ -</u>	<u>\$ -</u>
City Covered Payroll	\$ 5,456,921	\$ 5,396,935	\$ 5,466,539	\$ 5,445,025	\$ 5,092,704
Contributions as a Percentage of Covered Payroll	0.00%	0.01%	1.00%	2.00%	2.00%

(1) Information prior to 2015 is not available. Schedule is intended to show ten years of information, and additional years' will be displayed as it becomes available.

See accompanying notes to the required supplementary information

City of Brook Park, Ohio
Required Supplementary Information
Schedule of the City's Contributions – Net OPEB Liability
Ohio Police and Fire Pension Fund
Last Ten Years

	<u>2019</u>	<u>2018</u>	<u>2017</u>	<u>2016</u>	<u>2015</u>	<u>2014</u>	<u>2013</u>	<u>2012</u>	<u>2011</u>	<u>2010</u>
Contractually Required Contribution	\$ 32,809	\$ 32,077	\$ 31,203	\$ 29,316	\$ 27,430	\$ 30,831	\$ 213,304	\$ 408,091	\$ 420,031	\$ 425,422
Contributions in Relation to the Contractually Required Contribution	<u>(32,809)</u>	<u>(32,077)</u>	<u>(31,203)</u>	<u>(29,316)</u>	<u>(27,430)</u>	<u>(30,831)</u>	<u>(213,304)</u>	<u>(408,091)</u>	<u>(420,031)</u>	<u>(425,422)</u>
Contribution Deficiency (Excess)	<u>\$ -</u>	<u>\$ -</u>	<u>\$ -</u>	<u>\$ -</u>	<u>\$ -</u>	<u>\$ -</u>	<u>\$ -</u>	<u>\$ -</u>	<u>\$ -</u>	<u>\$ -</u>
City Covered Payroll	\$ 6,561,815	\$ 6,415,429	\$ 6,240,534	\$ 5,863,111	\$ 5,486,009	\$ 6,166,258	\$ 5,892,379	\$ 6,045,797	\$ 6,222,676	\$ 6,302,544
Contributions as a Percentage of Covered Payroll	0.50%	0.50%	0.50%	0.50%	0.50%	0.50%	3.62%	6.75%	6.75%	6.75%

See accompanying notes to the required supplementary information

City of Brook Park, Ohio
 Required Supplementary Information
 Schedule of the City's Contributions - Net OPEB Liability
 Other Post-Employment Benefits – Single Employer
Last Three Years

	<u>2019</u>	<u>2018</u>	<u>2017</u>
Contractually Required Contribution	\$ 93,076	\$ 102,714	\$ 217,407
Contributions in Relation to the Contractually Required Contribution	<u>(93,076)</u>	<u>(102,714)</u>	<u>(217,407)</u>
Contribution Deficiency (Excess)	<u>\$ -</u>	<u>\$ -</u>	<u>\$ -</u>
City Covered Payroll	\$ 12,018,736	\$ 11,812,364	\$ 11,707,073
Contributions as a Percentage of Covered Payroll	0.77%	0.87%	1.86%

(1) Information prior to 2017 is not available. Schedule is intended to show ten years of information, and additional years' will be displayed as it becomes available.

See accompanying notes to the required supplementary information

City of Brook Park, Ohio

Notes to the Required Supplementary Information
For the Year Ended December 31, 2019

OHIO PUBLIC EMPLOYEES RETIREMENT SYSTEM (OPERS)

Net Pension Liability

Changes in benefit terms: There were no changes in benefit terms from the amounts reported for 2014-2019.

Changes in assumptions: There were no changes in methods and assumptions used in the calculation of actuarial determined contributions for 2014-2016 and 2018. For 2017, the following changes of assumptions affected the total pension liability since the prior measurement date: (a) the expected investment return was reduced from 8.00% to 7.50%, (b) the expected long-term average wage inflation rate was reduced from 3.75% to 3.25%, (c) the expected long-term average price inflation rate was reduced from 3.00% to 2.50%, (d) Rates of withdrawal, retirement and disability were updated to reflect recent experience, (e) mortality rates were updated to the RP-2014 Health Annuitant Mortality Table, adjusted for mortality improvement back to the observant period base year of 2006 and then established the base year as 2015 (f) mortality rates used in evaluating disability allowances were updated to the RP-2014 Disabled Mortality tables, adjusted for mortality improvement back to the observation base year of 2006 and a base year of 2015 for males and 2010 for females (g) Mortality rates for a particular calendar year for both healthy and disabled retiree mortality tables are determined by applying the MP-2015 mortality improvement scale to the above described tables. For 2019, the following changes of assumptions affected the total pension liability since the prior measurement date: (a) the expected investment return was reduced from 7.50% to 7.20%.

Net OPEB Liability

Changes in benefit terms: There were no changes in benefit terms from the amounts reported for 2018-2019.

Changes in assumptions: For 2018, the single discount rate changed from 4.23% to 3.85%. For 2019, the following changes of assumptions affected the total OPEB liability since the prior measurement date: (a) the expected investment return was reduced from 6.50% to 6.00% (b) In January 2020, the Board adopted changes to health care coverage for Medicare and pre-Medicare retirees. It will include discontinuing the PPO plan for pre-Medicare retirees and replacing it with a monthly allowance to help participants pay for a health care plan of their choosing. The base allowance for Medicare eligible retirees will be reduced. The specific effect of these changes on the net OPEB liability and OPEB expense are unknown at this time.

City of Brook Park, Ohio

Notes to the Required Supplementary Information
For the Year Ended December 31, 2019

OHIO POLICE AND FIRE (OP&F) PENSION FUND

Net Pension Liability

Changes in benefit terms: There were no changes in benefit terms from the amounts reported for 2014-2019.

Changes in assumptions: There were no changes in methods and assumptions used in the calculation of actuarial determined contributions for 2014-2017. For 2018, the following changes of assumptions affected the total pension liability since the prior measurement date: (a) the investment rate of return was reduced from 8.25 percent to 8.00 percent (b) the projected salary increases was reduced from 4.25% to 3.75% (c) the payroll increases was reduced from 3.75% to 3.25% (d) the inflation assumptions was reduced from 3.25% to 2.75% (e) the cost of living adjustments was reduced from 2.60% to 2.20% (f) rates of withdrawal, disability and service retirement were updated to reflect recent experience (g) mortality rates were updated to the RP-2014 Total Employee and Health Annuitant Mortality Table, adjusted for mortality improvement back to the observant period base year of 2006 and then established the base year as 2016 (h) mortality rates used in evaluating disability allowances were updated to the RP-2014 Disabled Mortality tables, adjusted for mortality improvement back to the observation base year of 2006 and a base year of 2016. For 2019; There have been no OP&F pension plan amendments adopted or changes in assumptions between the measurement date and the report date that would have impacted the actuarial valuation of the pension plan as of the measurement date.

Net OPEB Liability

Changes in benefit terms: There were no changes in benefit terms from the amounts reported for 2018. For 2019, see below regarding changes to stipend-based model.

Changes in assumptions: For 2018, the single discount rate changed from 3.79 percent to 3.24 percent. For 2019, the changes of assumptions were: (a) beginning January 1, 2019 OP&F changed its retiree health care model and the current self-insured health care plan is no longer offered. In its place will be a stipend-based health care model. OP&F has contracted with a vendor who will assist eligible retirees in choosing health care plans from their marketplace (both Medicare-eligible and pre-Medicare populations). A stipend funded by OP&F will be placed in individual Health Reimbursement Accounts that retirees will use to be reimbursed for health care expenses. As a result of changing from the current health care model to the stipend based health care model, management expects that it will be able to provide stipends to eligible participants for the next 15 years (b) beginning in 2020 the Board approved a change to the Deferred Retirement Option Plan. The minimum interest rate accruing will be 2.5%

Combining Statements

City of Brook Park, Ohio

Fund Descriptions

Non-Major Governmental Funds

For The Year Ended December 31, 2019

Non-Major Special Revenue Funds

Street Maintenance Fund

The Street Maintenance Fund accounts for ninety-two and one half percent (92.5%) of the state gasoline tax and motor vehicle registration fees restricted for street maintenance and repair.

State Highway Fund

The State Highway Fund accounts for seven and one half percent (7.5%) of the state gasoline tax and motor vehicle registration fees restricted for maintenance and repair of state highways within the City.

Permissive Tax Fund

The Permissive Tax Fund accounts for additional motor vehicle registration fees restricted for maintenance and repair of streets within the City.

Economic Development Fund

The Economic Development Fund accounts for parking fees and proceeds received from the sale of City owned property committed for expenditures essential to the development of the City.

Brook Park Road Corridor Fund

The Brook Park Road Corridor Fund accounts for funds received from the City of Cleveland as a result of a legal settlement committed for attorney fees, land acquisition, grants or loans to Brook Park Road businesses and other expenditures related to the overall improvement of the corridor.

CDBG Fund

The CDBG Fund accounts for funds received from the Community Development Block Grant passed through from the Cuyahoga County. The grant funds were utilized for the W. 147th/Elm Street road project.

Special Recreation Fund

The Special Recreation Fund accounts for operations of City sponsored recreation programs committed by participation fees and facility rentals.

Law Enforcement Fund

The Law Enforcement Fund accounts for confiscated monies from criminal offenses and restricted, by state statute, for expenditures that would enhance the operation of the police department.

DWI Enforcement and Education Fund

The DWI Enforcement and Education Fund accounts for fine monies used by the law enforcement agency to pay costs related to DWI enforcement and for educating the public about laws governing the operation of a motor vehicle under the influence of alcohol.

Federal Forfeiture Fund

The Federal Forfeiture Fund accounts for confiscated monies from a Federal task force and restricted for expenditures that would enhance the operation of the police department.

City of Brook Park, Ohio

Fund Descriptions

Non-Major Governmental Funds

For The Year Ended December 31, 2019

Non-Major Special Revenue Funds (continued)

Community Diversion Fund

The Community Diversion Fund accounts for reimbursements received from Cuyahoga County Juvenile Court to promote and develop a community diversion program to address juvenile misdemeanor and status offenders.

Retiree Accrued Benefits Fund

The Retiree Accrued Benefits Fund accounts for funds allocated to pay for the accrued compensated absences paid out to employees upon retirement. Due to the implementation of GASB Statement No. 54, the fund was combined with the General Fund on the governmental fund financial statements but remained a separate fund in the budgetary schedules because it has a separate legally adopted budget.

Continuing Training Program Fund

The Continuing Training Program Fund accounts for restricted funds to provide for the training of the City's safety forces.

FEMA Fund

The FEMA Fund accounts for restricted funds that are used to reimburse costs incurred as a result of a natural disaster.

Police Pension Fund

The Police Pension Fund accounts for the accumulation of property taxes levied for the payment of current employer's pension contributions.

Fire Pension Fund

The Fire Pension Fund accounts for the accumulation of property taxes levied for the payment of current employer's pension contributions.

Southwest General Health Center Fund

The Southwest General Health Center Fund accounts for a special property tax levied to provide resources to support a health care facility.

Cash Bonds Held Fund

The Cash Bonds Held Fund accounts for deposits to insure the proper repair of street openings.

Non-Major Debt Service Fund

General Obligation Debt Service Fund

The General Obligation Debt Service Fund accounts for the resources that are used for payment of principal and interest and fiscal charges on general obligation debt.

City of Brook Park, Ohio
Combining Balance Sheet
Non-Major Governmental Funds
December 31, 2019

	Nonmajor Special Revenue Funds	Nonmajor Debt Service Fund	Total Nonmajor Governmental Funds
Assets:			
Equity in Pooled Cash and Cash Equivalents	\$ 4,104,417	\$ 1,338,379	\$ 5,442,796
Accrued Interest Receivable	3,293	-	3,293
Intergovernmental Receivable	534,392	633,534	1,167,926
Property Taxes Receivable	345,489	-	345,489
Special Assessments Receivable	-	29,197	29,197
Total Assets	4,987,591	2,001,110	6,988,701
Liabilities:			
Accounts Payable	\$ 23,986	\$ -	\$ 23,986
Accrued Wages and Benefits	9,122	-	9,122
Intergovernmental Payable	35,447	-	35,447
Unearned Revenue	96,689	-	96,689
Total Liabilities	165,244	-	165,244
Deferred Inflows of Resources:			
Property Taxes	331,697	-	331,697
Unavailable Revenue - Delinquent Property Taxes	13,792	-	13,792
Unavailable Revenue - Other	339,241	29,197	368,438
Total Deferred Inflows of Resources	684,730	29,197	713,927
Fund Balances:			
Restricted	2,617,497	661,977	3,279,474
Committed	1,520,120	-	1,520,120
Assigned	-	1,309,936	1,309,936
Total Fund Balances	4,137,617	1,971,913	6,109,530
Total Liabilities, Deferred Inflows of Resources and Fund Balances	\$ 4,987,591	\$ 2,001,110	\$ 6,988,701

City of Brook Park, Ohio

Combining Statement of Revenues, Expenditures and Changes in Fund Balances

Non-Major Governmental Funds

For The Year Ended December 31, 2019

	Nonmajor Special Revenue Funds	Nonmajor Debt Service Fund	Total Nonmajor Governmental Funds
REVENUES			
Property Taxes	\$ 341,644	\$ -	\$ 341,644
Intergovernmental	1,487,924	-	1,487,924
Interest	41,919	-	41,919
Licenses and Permits	70,245	-	70,245
Fines and Forfeitures	2,766	-	2,766
Charges for Services	119,816	-	119,816
Contributions and Donations	2,822	-	2,822
Special Assessments	-	77,808	77,808
Total Revenues	<u>2,067,136</u>	<u>77,808</u>	<u>2,144,944</u>
EXPENDITURES			
Security of Persons and Property:			
Police and Others	696,547	-	696,547
Fire	781,747	-	781,747
Public Health and Welfare	111,522	-	111,522
Leisure Time Activities	106,483	-	106,483
Community Development	447,504	-	447,504
Transportation	587,137	-	587,137
General Government	-	4,519	4,519
Debt Service:			
Principal Retirement	-	745,830	745,830
Interest and Fiscal Charges	-	376,900	376,900
Total Expenditures	<u>2,730,940</u>	<u>1,127,249</u>	<u>3,858,189</u>
Excess of Revenues Over (Under) Expenditures	<u>(663,804)</u>	<u>(1,049,441)</u>	<u>(1,713,245)</u>
OTHER FINANCING SOURCES			
Sale of Capital Assets	529,039	-	529,039
Transfer In	1,410,000	1,000,735	2,410,735
Transfer Out	(112,602)	-	(112,602)
Total Other Financing Sources	<u>1,826,437</u>	<u>1,000,735</u>	<u>2,827,172</u>
Net Change in Fund Balances	1,162,633	(48,706)	1,113,927
Fund Balances - Beginning of Year	2,974,984	2,020,619	4,995,603
Fund Balances - End of Year	<u>\$ 4,137,617</u>	<u>\$ 1,971,913</u>	<u>\$ 6,109,530</u>

City of Brook Park, Ohio
Combining Balance Sheet
Non-Major Special Revenue Funds
December 31, 2019

	Street Maintenance	State Highway	Permissive Tax	Economic Development	Brook Park Road Corridor
ASSETS					
Equity in Pooled Cash and Cash Equivalents	\$ 843,698	\$ 801,843	\$ 253,262	\$ 1,006,764	\$ 57,835
Accrued Interest Receivable	1,326	1,201	380	-	-
Intergovernmental Receivable	471,139	38,201	3,711	-	-
Property Taxes Receivable	-	-	-	-	-
Total Assets	1,316,163	841,245	257,353	1,006,764	57,835
LIABILITIES, DEFERRED INFLOWS OF RESOURCES AND FUND BALANCES					
Liabilities:					
Accounts Payable	\$ -	\$ -	\$ -	\$ 16,550	\$ -
Accrued Wages and Benefits	9,122	-	-	-	-
Intergovernmental Payable	1,277	-	-	-	-
Unearned Revenue	-	-	-	-	-
<i>Total Liabilities</i>	<u>10,399</u>	<u>-</u>	<u>-</u>	<u>16,550</u>	<u>-</u>
Deferred Inflows of Resources:					
Property Taxes	-	-	-	-	-
Unavailable Revenue - Delinq. Property Taxes	-	-	-	-	-
Unavailable Revenue - Other	294,054	23,846	-	-	-
<i>Total Deferred Inflows of Resources</i>	<u>294,054</u>	<u>23,846</u>	<u>-</u>	<u>-</u>	<u>-</u>
Fund Balances:					
Restricted	1,011,710	817,399	257,353	-	-
Committed	-	-	-	990,214	57,835
<i>Total Fund Balances</i>	<u>1,011,710</u>	<u>817,399</u>	<u>257,353</u>	<u>990,214</u>	<u>57,835</u>
Total Liabilities, Deferred Inflows of Resources and Fund Balances	\$ 1,316,163	\$ 841,245	\$ 257,353	\$ 1,006,764	\$ 57,835

(Continued)

City of Brook Park, Ohio
Combining Balance Sheet
Non-Major Special Revenue Funds
December 31, 2019

	CDBG	Special Recreation	Law Enforcement	DWI Enforcement & Education	Federal Forfeiture	Community Diversion
ASSETS						
Equity in Pooled Cash and Cash Equivalents	\$ 36,290	\$ 477,907	\$ 73,229	\$ 28,040	\$ 260,157	\$ 19,797
Accrued Interest Receivable	-	-	-	-	386	-
Intergovernmental Receivable	-	-	-	-	-	-
Property Taxes Receivable	-	-	-	-	-	-
Total Assets	<u>36,290</u>	<u>477,907</u>	<u>73,229</u>	<u>28,040</u>	<u>260,543</u>	<u>19,797</u>
LIABILITIES, DEFERRED INFLOWS OF RESOURCES AND FUND BALANCES						
Liabilities:						
Accounts Payable	\$ -	\$ 5,836	\$ 1,600	\$ -	\$ -	\$ -
Accrued Wages and Benefits	-	-	-	-	-	-
Intergovernmental Payable	-	-	-	-	-	-
Deferred Revenue	-	-	-	-	-	-
<i>Total Liabilities</i>	<u>-</u>	<u>5,836</u>	<u>1,600</u>	<u>-</u>	<u>-</u>	<u>-</u>
Deferred Inflows of Resources:						
Property Taxes	-	-	-	-	-	-
Unavailable Revenue - Delinq. Property Taxes	-	-	-	-	-	-
Unavailable Revenue - Other	-	-	-	-	-	-
<i>Total Deferred Inflows of Resources</i>	<u>-</u>	<u>-</u>	<u>-</u>	<u>-</u>	<u>-</u>	<u>-</u>
Fund Balances:						
Restricted	36,290	-	71,629	28,040	260,543	19,797
Committed	-	472,071	-	-	-	-
<i>Total Fund Balances</i>	<u>36,290</u>	<u>472,071</u>	<u>71,629</u>	<u>28,040</u>	<u>260,543</u>	<u>19,797</u>
Total Liabilities, Deferred Inflows of Resources and Fund Balances	<u>\$ 36,290</u>	<u>\$ 477,907</u>	<u>\$ 73,229</u>	<u>\$ 28,040</u>	<u>\$ 260,543</u>	<u>\$ 19,797</u>

Continuing Training Program	FEMA	Police Pension	Fire Pension	Southwest General Health Center	Cash Bonds Held	Total Nonmajor Special Revenue Funds
\$ 23,233	\$ 54,663	\$ 32,838	\$ 38,172	\$ -	\$ 96,689	\$ 4,104,417
-	-	-	-	-	-	3,293
-	-	7,471	7,471	6,399	-	534,392
-	-	122,800	122,800	99,889	-	345,489
<u>23,233</u>	<u>54,663</u>	<u>163,109</u>	<u>168,443</u>	<u>106,288</u>	<u>96,689</u>	<u>4,987,591</u>
\$ -	\$ -	\$ -	\$ -	\$ -	\$ -	\$ 23,986
-	-	-	-	-	-	9,122
-	-	15,945	18,225	-	-	35,447
-	-	-	-	-	96,689	96,689
<u>-</u>	<u>-</u>	<u>15,945</u>	<u>18,225</u>	<u>-</u>	<u>96,689</u>	<u>165,244</u>
-	-	117,906	117,906	95,885	-	331,697
-	-	4,894	4,894	4,004	-	13,792
-	-	7,471	7,471	6,399	-	339,241
<u>-</u>	<u>-</u>	<u>130,271</u>	<u>130,271</u>	<u>106,288</u>	<u>-</u>	<u>684,730</u>
23,233	54,663	16,893	19,947	-	-	2,617,497
-	-	-	-	-	-	1,520,120
<u>23,233</u>	<u>54,663</u>	<u>16,893</u>	<u>19,947</u>	<u>-</u>	<u>-</u>	<u>4,137,617</u>
<u>\$ 23,233</u>	<u>\$ 54,663</u>	<u>\$ 163,109</u>	<u>\$ 168,443</u>	<u>\$ 106,288</u>	<u>\$ 96,689</u>	<u>\$ 4,987,591</u>

City of Brook Park, Ohio

Combining Statement of Revenues, Expenditures and Changes in Fund Balances

Non-Major Special Revenue Funds

For The Year Ended December 31, 2019

	Street Maintenance	State Highway	Permissive Tax	Economic Development	Brook Park Road Corridor	CDBG	Special Recreation
REVENUES							
Property Taxes	\$ -	\$ -	\$ -	\$ -	\$ -	\$ -	\$ -
Intergovernmental	985,851	79,932	46,868	217,887	-	112,602	-
Interest	14,071	16,880	5,246	-	-	-	-
Fees, Licenses, and Permits	-	-	-	70,245	-	-	-
Fines and Forfeitures	-	-	-	-	-	-	-
Charges for Services	-	-	-	3,006	-	-	116,810
Contributions and Donations	-	-	-	-	-	-	2,822
Total Revenues	<u>999,922</u>	<u>96,812</u>	<u>52,114</u>	<u>291,138</u>	<u>-</u>	<u>112,602</u>	<u>119,632</u>
EXPENDITURES							
Security of Persons and Property:							
Police and Others	-	-	-	-	-	-	-
Fire	-	-	-	-	-	-	-
Public Health and Welfare	-	-	-	-	-	-	-
Leisure Time Activities	-	-	-	-	-	-	106,483
Community Environment	-	-	-	447,504	-	-	-
Transportation	566,671	6,646	13,820	-	-	-	-
Capital Outlay	-	-	-	-	-	-	-
Total Expenditures	<u>566,671</u>	<u>6,646</u>	<u>13,820</u>	<u>447,504</u>	<u>-</u>	<u>-</u>	<u>106,483</u>
Excess of Revenues Over (Under) Expenditures	<u>433,251</u>	<u>90,166</u>	<u>38,294</u>	<u>(156,366)</u>	<u>-</u>	<u>112,602</u>	<u>13,149</u>
OTHER FINANCING SOURCES							
Sale of Capital Assets	-	-	-	529,039	-	-	-
Transfer In	-	-	-	200,000	-	-	-
Transfer Out	-	-	-	-	-	(112,602)	-
	-	-	-	-	-	-	-
Total Other Financing Sources	<u>-</u>	<u>-</u>	<u>-</u>	<u>729,039</u>	<u>-</u>	<u>(112,602)</u>	<u>-</u>
Net Change in Fund Balances	<u>433,251</u>	<u>90,166</u>	<u>38,294</u>	<u>572,673</u>	<u>-</u>	<u>-</u>	<u>13,149</u>
Fund Balances - Beginning of Year	578,459	727,233	219,059	417,541	57,835	36,290	458,922
Fund Balances - End of Year	<u>\$ 1,011,710</u>	<u>\$ 817,399</u>	<u>\$ 257,353</u>	<u>\$ 990,214</u>	<u>\$ 57,835</u>	<u>\$ 36,290</u>	<u>\$ 472,071</u>

Law Enforcement	DWI Enforcement & Education	Federal Forfeiture	Community Diversion	Continuing Training Program	FEMA	Police Pension	Fire Pension	Southwest General Health Center	Cash Bonds Held	Total Nonmajor Special Revenue Funds
\$ -	\$ -	\$ -	\$ -	\$ -	\$ -	\$ 121,461	\$ 121,461	\$ 98,722	\$ -	\$ 341,644
-	-	-	2,100	-	-	14,942	14,942	12,800	-	1,487,924
-	-	5,722	-	-	-	-	-	-	-	41,919
-	-	-	-	-	-	-	-	-	-	70,245
1,210	1,556	-	-	-	-	-	-	-	-	2,766
-	-	-	-	-	-	-	-	-	-	119,816
-	-	-	-	-	-	-	-	-	-	2,822
<u>1,210</u>	<u>1,556</u>	<u>5,722</u>	<u>2,100</u>	<u>-</u>	<u>-</u>	<u>136,403</u>	<u>136,403</u>	<u>111,522</u>	<u>-</u>	<u>2,067,136</u>
18,016	863	-	74	-	-	677,594	-	-	-	696,547
-	-	-	-	-	-	-	781,747	-	-	781,747
-	-	-	-	-	-	-	-	111,522	-	111,522
-	-	-	-	-	-	-	-	-	-	106,483
-	-	-	-	-	-	-	-	-	-	447,504
-	-	-	-	-	-	-	-	-	-	587,137
-	-	-	-	-	-	-	-	-	-	-
<u>18,016</u>	<u>863</u>	<u>-</u>	<u>74</u>	<u>-</u>	<u>-</u>	<u>677,594</u>	<u>781,747</u>	<u>111,522</u>	<u>-</u>	<u>2,730,940</u>
<u>(16,806)</u>	<u>693</u>	<u>5,722</u>	<u>2,026</u>	<u>-</u>	<u>-</u>	<u>(541,191)</u>	<u>(645,344)</u>	<u>-</u>	<u>-</u>	<u>(663,804)</u>
-	-	-	-	-	-	-	-	-	-	529,039
-	-	-	-	-	-	530,000	680,000	-	-	1,410,000
-	-	-	-	-	-	-	-	-	-	(112,602)
-	-	-	-	-	-	-	-	-	-	-
-	-	-	-	-	-	530,000	680,000	-	-	1,826,437
<u>(16,806)</u>	<u>693</u>	<u>5,722</u>	<u>2,026</u>	<u>-</u>	<u>-</u>	<u>(11,191)</u>	<u>34,656</u>	<u>-</u>	<u>-</u>	<u>1,162,633</u>
88,435	27,347	254,821	17,771	23,233	54,663	28,084	(14,709)	-	-	2,974,984
<u>\$ 71,629</u>	<u>\$ 28,040</u>	<u>\$ 260,543</u>	<u>\$ 19,797</u>	<u>\$ 23,233</u>	<u>\$ 54,663</u>	<u>\$ 16,893</u>	<u>\$ 19,947</u>	<u>\$ -</u>	<u>\$ -</u>	<u>\$ 4,137,617</u>

**Individual Fund
Schedules of Revenues, Expenditures and
Changes in Fund Balances -
Budget (Non – GAAP Budgetary Basis) and Actual**

City of Brook Park, Ohio

Schedule of Revenues, Expenditures and Changes in Fund Balance - Budget (Non-GAAP Budgetary Basis) and Actual

General Fund

For The Year Ended December 31, 2019

	Budgeted Amounts		Actual	Variance with Final Budget Positive (Negative)
	Original	Final		
Revenues:				
Property Taxes	\$ 1,612,669	\$ 1,703,197	\$ 1,703,197	\$ -
Income Taxes	16,673,226	17,366,035	17,366,035	-
Other Taxes	354,300	344,814	344,814	-
Intergovernmental	582,409	671,685	671,685	-
Interest	175,875	168,140	168,140	-
Licenses and Permits	598,106	697,990	697,990	-
Fines and Forfeitures	515,000	625,041	625,041	-
Rentals	50,165	50,165	50,165	-
Charges for Services	1,866,257	2,225,387	2,225,387	-
Contributions and Donations	3,547	3,547	3,547	-
All Other Revenues	51,918	42,604	42,604	-
Total Revenues	22,483,472	23,898,605	23,898,605	-
Expenditures:				
Current:				
Security of Persons and Property				
Correctional Facility				
Personal Services	215,377	215,377	210,795	4,582
Operations	48,934	48,934	39,944	8,990
Total Correctional Facility	264,311	264,311	250,739	13,572
School Guards				
Personal Services	83,814	83,814	80,266	3,548
Total School Guards	83,814	83,814	80,266	3,548
Fire Department				
Personal Services	4,052,183	4,052,183	3,838,769	213,414
Operations	246,236	371,392	357,553	13,839
Total Fire Department	4,298,419	4,423,575	4,196,322	227,253
Police Department				
Personal Services	4,321,652	4,388,095	4,354,198	33,897
Operations	255,975	258,475	240,441	18,034
Total Police Department	4,577,627	4,646,570	4,594,639	51,931

Continued

City of Brook Park, Ohio

Schedule of Revenues, Expenditures and Changes in Fund Balance - Budget (Non-GAAP Budgetary Basis) and Actual

General Fund (continued)

For The Year Ended December 31, 2019

	Budgeted Amounts		Actual	Variance with Final Budget Positive (Negative)
	Original	Final		
Animal Control				
Personal Services	100,292	100,292	96,358	3,934
Operations	18,756	21,506	18,744	2,762
Total Animal Control	119,048	121,798	115,102	6,696
Safety Building				
Personal Services	60,494	60,495	58,823	1,672
Operations	1,155,286	1,155,286	604,810	550,476
Total Safety Building	1,215,780	1,215,781	663,633	552,148
Safety Town				
Operations	4,000	4,194	4,194	-
Total Safety Town	4,000	4,194	4,194	-
Street Lighting				
Operations	403,000	403,000	380,313	22,687
Total Street Lighting	403,000	403,000	380,313	22,687
Traffic Lights				
Operations	70,289	80,289	74,945	5,344
Total Traffic Lights	70,289	80,289	74,945	5,344

Continued

City of Brook Park, Ohio

Schedule of Revenues, Expenditures and Changes in Fund Balance - Budget (Non-GAAP Budgetary Basis) and Actual

General Fund (continued)

For The Year Ended December 31, 2019

	Budgeted Amounts		Actual	Variance with Final Budget Positive (Negative)
	Original	Final		
Disaster Services				
Personal Services	11,082	16,855	13,874	2,981
Operations	9,250	8,250	7,463	787
Total Disaster Services	20,332	25,105	21,337	3,768
Total Security of Persons and Property	11,056,620	11,268,437	10,381,490	886,947
Public Health & Welfare				
County Board of Health				
Operations	91,065	91,065	91,065	-
Total County Board of Health	91,065	91,065	91,065	-
Office of Aging				
Personal Services	36,263	39,726	38,923	803
Operations	4,591	5,091	4,191	900
Total Office of Aging	40,854	44,817	43,114	1,703
Total Public Health and Welfare	131,919	135,882	134,179	1,703
Leisure Time Activities				
Recreation Commission				
Personal Services	6,927	7,851	6,927	924
Operations	-	1,144	949	195
Total Recreation Commission	6,927	8,995	7,876	1,119
Recreation Center				
Personal Services	564,622	576,167	561,007	15,160
Operations	211,778	211,778	183,284	28,494
Other Expenses	250	1,000	895	105
Total Recreation Center	776,650	788,945	745,186	43,759
Home Day Celebration				
Personal Services	24,061	16,107	16,107	-
Operations	47,550	47,550	45,408	2,142
Total Home Day Celebration	71,611	63,657	61,515	2,142

Continued

City of Brook Park, Ohio

Schedule of Revenues, Expenditures and Changes in Fund Balance - Budget (Non-GAAP Budgetary Basis) and Actual

General Fund (continued)

For The Year Ended December 31, 2019

	Budgeted Amounts		Actual	Variance with Final Budget Positive (Negative)
	Original	Final		
Parks and Play Grounds				
Personal Services	241,774	237,444	232,622	4,822
Operations	135,727	145,260	135,933	9,327
Other Expenses	500	400	400	-
Total Parks and Play Grounds	378,001	383,104	368,955	14,149
Public Recreation				
Personal Services	22,531	22,531	17,744	4,787
Operations	28,730	28,730	25,463	3,267
Total Public Recreation	51,261	51,261	43,207	8,054
Total Leisure Time Activities	1,284,450	1,295,962	1,226,739	69,223
Community Development				
Planning Commission				
Personal Services	6,927	6,927	6,927	-
Total Planning Commission	6,927	6,927	6,927	-
Community Development				
Personal Services	114,705	114,705	107,747	6,958
Operations	3,100	3,100	2,676	424
Total Community Development	117,805	117,805	110,423	7,382
Board of Zoning Appeals				
Personal Services	9,698	9,698	7,966	1,732
Operations	100	100	-	100
Total Board of Zoning Appeals	9,798	9,798	7,966	1,832
Building Department				
Personal Services	515,579	515,579	502,719	12,860
Operations	58,156	59,256	49,750	9,506
Other Expenses	250	250	60	190
Total Building Department	573,985	575,085	552,529	22,556

Continued

City of Brook Park, Ohio

Schedule of Revenues, Expenditures and Changes in Fund Balance - Budget (Non-GAAP Budgetary Basis) and Actual

General Fund (continued)

For The Year Ended December 31, 2019

	Budgeted Amounts		Actual	Variance with Final Budget Positive (Negative)
	Original	Final		
Tree and Tree Lawns				
Personal Services	174,856	178,320	173,193	5,127
Operations	25,626	25,626	14,223	11,403
Total Tree and Tree Lawns	200,482	203,946	187,416	16,530
Total Community Development	908,997	913,561	865,261	48,300
Public Works				
Service Director				
Personal Services	129,628	129,628	122,916	6,712
Operations	13,835	13,835	8,236	5,599
Total Service Director	143,463	143,463	131,152	12,311
Service Building				
Personal Services	90,682	90,682	83,108	7,574
Operations	227,886	227,886	177,866	50,020
Total Service Building	318,568	318,568	260,974	57,594
Sanitation Department				
Personal Services	444,053	444,053	441,247	2,806
Operations	644,891	664,891	636,924	27,967
Total Sanitation Department	1,088,944	1,108,944	1,078,171	30,773
Sewers, Drains, and Pump Stations				
Personal Services	678,821	678,821	665,161	13,660
Operations	156,864	158,364	131,059	27,305
Total Sewers, Drains, and Pump Stations	835,685	837,185	796,220	40,965
Total Public Works	2,386,660	2,408,160	2,266,517	141,643

Continued

City of Brook Park, Ohio

Schedule of Revenues, Expenditures and Changes in Fund Balance - Budget (Non-GAAP Budgetary Basis) and Actual

General Fund (continued)

For The Year Ended December 31, 2019

	Budgeted Amounts		Actual	Variance with Final Budget Positive (Negative)
	Original	Final		
Transportation				
Street Cleaning				
Personal Services	90,267	90,267	55,634	34,633
Operations	4,950	4,950	2,503	2,447
Total Street Cleaning	95,217	95,217	58,137	37,080
Traffic Signs				
Personal Services	77,077	77,077	76,303	774
Operations	4,100	5,100	4,128	972
Total Traffic Signs	81,177	82,177	80,431	1,746
Snow Removal				
Personal Services	115,450	115,450	79,988	35,462
Operations	437,865	437,865	320,984	116,881
Total Snow Removal	553,315	553,315	400,972	152,343
Total Transportation	729,709	730,709	539,540	191,169
General Government				
City Council				
Personal Services	143,121	143,121	143,121	-
Operations	24,071	28,571	23,575	4,996
Total City Council	167,192	171,692	166,696	4,996
Clerk of Council				
Personal Services	102,807	90,807	80,402	10,405
Operations	4,550	4,550	1,224	3,326
Total Clerk of Council	107,357	95,357	81,626	13,731

Continued

City of Brook Park, Ohio

Schedule of Revenues, Expenditures and Changes in Fund Balance - Budget (Non-GAAP Budgetary Basis) and Actual

General Fund (continued)

For The Year Ended December 31, 2019

	Budgeted Amounts		Actual	Variance with Final Budget Positive (Negative)
	Original	Final		
Mayor's Court				
Personal Services	148,361	152,644	150,450	2,194
Operations	14,580	14,580	12,323	2,257
Total Mayor's Court	162,941	167,224	162,773	4,451
Civil Service Commission				
Personal Services	28,671	28,671	27,821	850
Operations	10,464	12,614	11,722	892
Total Civil Service Commission	39,135	41,285	39,543	1,742
Charter Review Commission				
Contractual Services	300	300	13	287
Total Charter Review Commission	300	300	13	287
Mayor's Office				
Personal Services	346,823	346,823	344,623	2,200
Operations	21,713	32,713	20,119	12,594
Total Mayor's Office	368,536	379,536	364,742	14,794
Human Resources				
Personal Services	102,208	102,208	89,576	12,632
Operations	11,609	11,609	6,304	5,305
Total Human Resources	113,817	113,817	95,880	17,937
Public Properties				
Personal Services	350,034	350,034	235,561	114,473
Operations	14,700	14,700	10,688	4,012
Total Public Properties	364,734	364,734	246,249	118,485

Continued

City of Brook Park, Ohio

Schedule of Revenues, Expenditures and Changes in Fund Balance - Budget (Non-GAAP Budgetary Basis) and Actual

General Fund (continued)

For The Year Ended December 31, 2019

	Budgeted Amounts		Actual	Variance with Final Budget Positive (Negative)
	Original	Final		
Legal Department				
Personal Services	348,162	348,162	297,567	50,595
Operations	8,953	10,453	8,836	1,617
Total Legal Department	357,115	358,615	306,403	52,212
Finance Department				
Personal Services	478,992	485,018	481,421	3,597
Operations	87,369	87,369	80,283	7,086
Total Finance Department	566,361	572,387	561,704	10,683
Tax Department				
Personal Services	265,233	265,233	252,415	12,818
Operations	115,931	115,939	50,034	65,905
Other Expenses	800,000	800,000	249,882	550,118
Total Tax Department	1,181,164	1,181,172	552,331	628,841
Retirees				
Personal Services	-	140,000	93,076	46,924
Operations	140,000	-	-	-
Total Retirees	140,000	140,000	93,076	46,924
Mechanics				
Personal Services	619,836	627,917	602,614	25,303
Operations	10,600	10,600	5,330	5,270
Total Mechanics	630,436	638,517	607,944	30,573
Engineering				
Operations	48,000	48,000	48,000	-
Total Engineering	48,000	48,000	48,000	-

Continued

City of Brook Park, Ohio

Schedule of Revenues, Expenditures and Changes in Fund Balance - Budget (Non-GAAP Budgetary Basis) and Actual

General Fund (continued)

For The Year Ended December 31, 2019

	Budgeted Amounts		Actual	Variance with Final Budget Positive (Negative)
	Original	Final		
Lands and Buildings				
Personal Services	1,732	5,195	1,567	3,628
Operations	166,254	155,800	124,801	30,999
Total Lands and Buildings	167,986	160,995	126,368	34,627
Other General Government				
Personal Services	338,000	338,000	277,033	60,967
Operations	684,220	658,315	567,956	90,359
Other Expenses	3,000	3,000	1,570	1,430
Total Other General Government	1,025,220	999,315	846,559	152,756
Total General Government	5,440,294	5,432,946	4,299,907	1,133,039
Total Expenditures	21,938,649	22,185,657	19,713,633	2,472,024
Excess of Revenues Over (Under) Expenditures	544,823	1,712,948	4,184,972	2,472,024
Other Financing Sources (Uses)				
Transfer In	152,602	593,588	593,588	-
Transfers Out	(2,220,689)	(3,011,190)	(3,011,190)	-
Total Other Financing Sources (Uses)	(2,068,087)	(2,417,602)	(2,417,602)	-
Net Change in Fund Balance	(1,523,264)	(704,654)	1,767,370	2,472,024
Cash Fund Balance - Beginning of Year	8,631,553	8,631,553	8,631,553	-
Current Year Encumbrances	-	-	197,320	197,320
Cash Fund Balance - End of Year	7,108,289	7,926,899	10,596,243	2,669,344

City of Brook Park, Ohio

Schedule of Revenues, Expenditures and Changes in Fund Balance - Budget (Non-GAAP Budgetary Basis) and Actual

Capital Improvements Fund

For The Year Ended December 31, 2019

	Budgeted Amounts		Actual	Variance with Final Budget Positive (Negative)
	Original	Final		
Revenues:				
Income Taxes	\$ 6,843,049	\$ 7,017,656	\$ 7,017,656	\$ -
Intergovernmental	1,569,928	1,364,139	1,364,139	-
Fines and Forfeitures	13,080	24,684	24,684	-
Charges for Services	1,526	2,880	2,880	-
All Other Revenues	13,207	24,922	24,922	-
Total Revenues	8,440,790	8,434,281	8,434,281	-
Expenditures:				
Community Development				
Operations	132,809	132,809	13,054	119,755
Total Community Development	132,809	132,809	13,054	119,755
Transportation				
Street Paving and Repair				
Operations	527,990	534,698	527,196	7,502
Total Transportation	527,990	534,698	527,196	7,502
General Government				
Income Tax Department				
Personal Services	58,457	58,457	55,334	3,123
Operaions	27,336	27,336	11,799	15,537
Other Expenses	200,000	200,000	62,470	137,530
Total Income Tax Department	285,793	285,793	129,603	156,190
Total General Government	285,793	285,793	129,603	156,190

Continued

City of Brook Park, Ohio

Schedule of Revenues, Expenditures and Changes in Fund Balance - Budget (Non-GAAP Budgetary Basis) and Actual

Capital Improvements Fund (continued)

For The Year Ended December 31, 2019

	Budgeted Amounts		Actual	Variance with Final Budget Positive (Negative)
	Original	Final		
Capital Outlay				
Building Department	23,001	23,001	22,857	144
Council	774	774	774	-
Finance Department	5,819	3,318	819	2,499
Fire Department	232,179	314,179	309,914	4,265
Lands and Buildings	178,009	145,707	130,888	14,819
Legal Department	3,762	3,762	3,753	9
Mayor's Court	8,175	9,425	9,268	157
Mayor's Office	1,603	3,603	3,431	172
Mechanics	-	1,000	975	25
Office of Aging	61,379	69,207	69,207	-
Police Department	154,370	144,370	137,871	6,499
Recreation Center	31,103	31,103	31,030	73
Safety Building	184,798	173,799	173,208	591
Sanitation	160,263	175,262	112,775	62,487
Service Building	52,996	7,996	4,944	3,052
Sewers and Drains	156,049	189,273	189,273	-
Snow Removal	129,678	117,678	115,767	1,911
Street Paving and Repair	5,689,301	4,729,062	4,709,905	19,157
Tax Department	5,229	2,730	230	2,500
Total Capital Outlay	7,078,488	6,145,249	6,026,889	118,360
Total Expenditures	8,025,080	7,098,549	6,696,742	401,807
Excess of Revenues Over (Under) Expenditures	415,710	1,335,732	1,737,539	401,807
Other Financing Sources (Uses)				
Sale of Capital Assets	9,655	18,219	18,219	-
OPWC Loans Issued	1,236,000	106,689	106,689	-
Transfers In	1,493,829	2,490,487	2,490,487	-
Transfers Out	(6,034,949)	(6,676,976)	(6,676,976)	-
Total Other Financing Sources (Uses)	(3,295,465)	(4,061,581)	(4,061,581)	-
Net Change in Fund Balance	(2,879,755)	(2,725,849)	(2,324,042)	401,807
Cash Fund Balance - Beginning of Year	3,671,654	3,671,654	3,671,654	-
Current Year Encumbrances	-	-	1,660,786	1,660,786
Cash Fund Balance - End of Year	\$ 791,899	\$ 945,805	\$ 3,008,398	\$ 2,062,593

See accompanying notes to the basic financial statements.

City of Brook Park, Ohio

Schedule of Revenues, Expenditures and Changes in Fund Balance - Budget (Non-GAAP Budgetary Basis) and Actual

Street Maintenance Fund

For The Year Ended December 31, 2019

	Budgeted Amounts		Variance with Final Budget Positive (Negative)
	Final	Actual	
Revenues:			
Intergovernmental	\$ 942,277	\$ 942,277	\$ -
Interest	13,741	13,741	-
Total Revenues	<u>956,018</u>	<u>956,018</u>	<u>-</u>
Expenditures:			
Current:			
Transportation			
Street Paving and Repair			
Personal Services	505,100	481,528	23,572
Operations	123,525	91,063	32,462
Total Expenditures	<u>628,625</u>	<u>572,591</u>	<u>56,034</u>
Net Change in Fund Balance	327,393	383,427	56,034
Cash Fund Balance - Beginning of Year	453,304	453,304	-
Current Year Encumbrances	-	6,967	6,967
Cash Fund Balance - End of Year	<u>\$ 780,697</u>	<u>\$ 843,698</u>	<u>\$ 63,001</u>

City of Brook Park, Ohio

Schedule of Revenues, Expenditures and Changes in Fund Balance -
Budget (Non-GAAP Budgetary Basis) and Actual

State Highway Fund

For The Year Ended December 31, 2019

	Budgeted Amounts		Variance with Final Budget Positive (Negative)
	Final	Actual	
Revenues:			
Intergovernmental	\$ 76,401	\$ 76,401	\$ -
Interest	17,203	17,203	-
Total Revenues	<u>93,604</u>	<u>93,604</u>	<u>-</u>
Expenditures:			
Current:			
Transportation			
Street Paving and Repair			
Personal Services	173	49	124
Operations	33,388	6,645	26,743
Total Expenditures	<u>33,561</u>	<u>6,694</u>	<u>26,867</u>
Net Change in Fund Balance	60,043	86,910	26,867
Cash Fund Balance - Beginning of Year	714,885	714,885	-
Current Year Encumbrances	-	48	48
Cash Fund Balance - End of Year	<u>\$ 774,928</u>	<u>\$ 801,843</u>	<u>\$ 26,915</u>

City of Brook Park, Ohio

Schedule of Revenues, Expenditures and Changes in Fund Balance - Budget (Non-GAAP Budgetary Basis) and Actual

Permissive Tax Fund

For The Year Ended December 31, 2019

	Budgeted Amounts		Variance with Final Budget Positive (Negative)
	Final	Actual	
Revenues:			
Intergovernmental	\$ 46,725	\$ 46,725	\$ -
Interest	5,326	5,326	-
Total Revenues	<u>52,051</u>	<u>52,051</u>	<u>-</u>
Expenditures:			
Current:			
Transportation			
Street Paving and Repair			
Operations	<u>56,958</u>	<u>18,749</u>	<u>38,209</u>
Capital Outlay			
Contractual Services	<u>78,361</u>	<u>78,361</u>	<u>-</u>
Total Expenditures	<u>135,319</u>	<u>97,110</u>	<u>38,209</u>
Net Change in Fund Balance	(83,268)	(45,059)	38,209
Cash Fund Balance - Beginning of Year	215,980	215,980	-
Current Year Encumbrances	-	82,341	82,341
Cash Fund Balance - End of Year	<u>\$ 132,712</u>	<u>\$ 253,262</u>	<u>\$ 120,550</u>

City of Brook Park, Ohio

Schedule of Revenues, Expenditures and Changes in Fund Balance - Budget (Non-GAAP Budgetary Basis) and Actual

Economic Development Fund

For The Year Ended December 31, 2019

	Budgeted Amounts		Variance with Final Budget Positive (Negative)
	Final	Actual	
Revenues:			
Intergovernmental	\$ 217,887	\$ 217,887	\$ -
Fees, Licenses, and Permits	70,245	70,245	-
Charges for Services	3,006	3,006	-
Total Revenues	<u>291,138</u>	<u>291,138</u>	<u>-</u>
Expenditures:			
Current:			
Community Environment			
Operations	903,633	889,623	14,010
Total Expenditures	<u>903,633</u>	<u>889,623</u>	<u>14,010</u>
Excess of Revenues Over (Under) Expenditures	(612,495)	(598,485)	14,010
Other Financing Sources			
Sale of Capital Assets	529,039	529,039	-
Transfers In	200,000	200,000	-
Total Other Financing Sources	<u>729,039</u>	<u>729,039</u>	<u>-</u>
Net Change in Fund Balance	116,544	130,554	14,010
Cash Fund Balance - Beginning of Year	441,361	441,361	-
Current Year Encumbrances	-	434,849	434,849
Cash Fund Balance - End of Year	<u>\$ 557,905</u>	<u>\$ 1,006,764</u>	<u>\$ 448,859</u>

City of Brook Park, Ohio

Schedule of Revenues, Expenditures and Changes in Fund Balance -
Budget (Non-GAAP Budgetary Basis) and Actual

Brook Park Road Corridor Fund

For The Year Ended December 31, 2019

	Budgeted Amounts		Variance with Final Budget Positive (Negative)
	Final	Actual	
Cash Fund Balance - Beginning of Year	\$ 57,835	\$ 57,835	\$ -
Cash Fund Balance - End of Year	\$ 57,835	\$ 57,835	\$ -

City of Brook Park, Ohio

Schedule of Revenues, Expenditures and Changes in Fund Balance -
Budget (Non-GAAP Budgetary Basis) and Actual
CDBG Fund

For The Year Ended December 31, 2019

	Budgeted Amounts		Variance with Final Budget Positive (Negative)
	<u>Final</u>	<u>Actual</u>	<u>(Negative)</u>
Revenues:			
Intergovernmental	\$ 112,602	\$ 112,602	\$ -
Total Revenues	<u>112,602</u>	<u>112,602</u>	<u>-</u>
Other Financing Uses			
Transfers Out	<u>(112,602)</u>	<u>(112,602)</u>	<u>-</u>
Total Other Financing Uses	<u>(112,602)</u>	<u>(112,602)</u>	<u>-</u>
Net Change in Fund Balance	-	-	-
Cash Fund Balance - Beginning of Year	\$ 36,290	\$ 36,290	\$ -
Cash Fund Balance - End of Year	<u>\$ 36,290</u>	<u>\$ 36,290</u>	<u>\$ -</u>

City of Brook Park, Ohio

Schedule of Revenues, Expenditures and Changes in Fund Balance - Budget (Non-GAAP Budgetary Basis) and Actual

Special Recreation Fund

For The Year Ended December 31, 2019

	Budgeted Amounts		Variance with Final Budget Positive (Negative)
	Final	Actual	
Revenues:			
Charges for Services	\$ 116,810	\$ 116,810	\$ -
Contributions and Donations	2,822	2,822	-
Total Revenues	<u>119,632</u>	<u>119,632</u>	<u>-</u>
Expenditures:			
Current:			
Leisure Time Activities			
Public Recreation			
Parks & Playground			
Operations	100,679	94,961	5,718
Other	1,500	1,100	400
Capital Outlay	27,526	20,370	7,156
Total Expenditures	<u>129,705</u>	<u>116,431</u>	<u>13,274</u>
Net Change in Fund Balance	(10,073)	3,201	13,274
Cash Fund Balance - Beginning of Year	458,923	458,923	-
Current Year Encumbrances	-	15,783	15,783
Cash Fund Balance - End of Year	<u>\$ 448,850</u>	<u>\$ 477,907</u>	<u>\$ 29,057</u>

City of Brook Park, Ohio

Schedule of Revenues, Expenditures and Changes in Fund Balance - Budget (Non-GAAP Budgetary Basis) and Actual

Law Enforcement Fund

For The Year Ended December 31, 2019

	Budgeted Amounts		Variance with Final Budget Positive (Negative)
	Final	Actual	
Revenues:			
Fines and Forfeitures	\$ 1,210	\$ 1,210	\$ -
Total Revenues	<u>1,210</u>	<u>1,210</u>	<u>-</u>
Expenditures:			
Current:			
Security of Persons and Property			
Police and Others			
Operations	6,000	4,800	1,200
Capital Outlay	23,000	13,216	9,784
Total Expenditures	<u>29,000</u>	<u>18,016</u>	<u>10,984</u>
Net Change in Fund Balance	(27,790)	(16,806)	10,984
Cash Fund Balance - Beginning of Year	88,435	88,435	-
Current Year Encumbrances	-	1,600	1,600
Cash Fund Balance - End of Year	<u>\$ 60,645</u>	<u>\$ 73,229</u>	<u>\$ 12,584</u>

City of Brook Park, Ohio

Schedule of Revenues, Expenditures and Changes in Fund Balance -
Budget (Non-GAAP Budgetary Basis) and Actual

DWI Enforcement and Education Fund

For The Year Ended December 31, 2019

	Budgeted Amounts		Variance with Final Budget Positive (Negative)
	Final	Actual	
Revenues:			
Fines and Forfeitures	\$ 1,556	\$ 1,556	\$ -
Total Revenues	<u>1,556</u>	<u>1,556</u>	<u>-</u>
Expenditures:			
Current:			
Security of Persons and Property			
Operations	5,000	863	4,137
Total Expenditures	<u>5,000</u>	<u>863</u>	<u>4,137</u>
Net Change in Fund Balance	(3,444)	693	4,137
Cash Fund Balance - Beginning of Year	27,347	27,347	-
Cash Fund Balance - End of Year	<u>\$ 23,903</u>	<u>\$ 28,040</u>	<u>\$ 4,137</u>

City of Brook Park, OhioSchedule of Revenues, Expenditures and Changes in Fund Balance -
Budget (Non-GAAP Budgetary Basis) and Actual

Federal Forfeiture Fund

For The Year Ended December 31, 2019

	Budgeted Amounts		Variance with Final Budget Positive (Negative)
	Final	Actual	
Revenues:			
Interest	\$ 5,874	\$ 5,874	\$ -
Total Revenues	<u>5,874</u>	<u>5,874</u>	<u>-</u>
Expenditures:			
Current:			
Security of Persons and Property			
Police and Others			
Operations	1,500	-	1,500
Capital Outlay	84,890	9,890	75,000
Total Expenditures	<u>86,390</u>	<u>9,890</u>	<u>76,500</u>
Net Change in Fund Balance	(80,516)	(4,016)	76,500
Cash Fund Balance - Beginning of Year	264,173	264,173	-
Cash Fund Balance - End of Year	<u>\$ 183,657</u>	<u>\$ 260,157</u>	<u>\$ 76,500</u>

City of Brook Park, Ohio

Schedule of Revenues, Expenditures and Changes in Fund Balance -
Budget (Non-GAAP Budgetary Basis) and Actual

Community Diversion Fund

For The Year Ended December 31, 2019

	Budgeted Amounts		Variance with Final Budget Positive (Negative)
	Final	Actual	
Revenues:			
Intergovernmental	\$ 2,100	\$ 2,100	\$ -
Total Revenues	<u>2,100</u>	<u>2,100</u>	<u>-</u>
Expenditures:			
Current:			
Security of Persons and Property			
Police and Others			
Personal Services	1,154	74	1,080
Operations	200	-	200
Total Expenditures	<u>1,354</u>	<u>74</u>	<u>1,280</u>
Net Change in Fund Balance	746	2,026	1,280
Cash Fund Balance - Beginning of Year	17,771	17,771	-
Cash Fund Balance - End of Year	<u>\$ 18,517</u>	<u>\$ 19,797</u>	<u>\$ 1,280</u>

City of Brook Park, Ohio

Schedule of Revenues, Expenditures and Changes in Fund Balance -
Budget (Non-GAAP Budgetary Basis) and Actual

Retiree Accrued Benefits Fund

For The Year Ended December 31, 2019

	Budgeted Amounts		Variance with Final Budget Positive (Negative)
	Final	Actual	
Expenditures:			
Current:			
Public Works			
Sewers and Drains			
Personal Services	\$ 280,000	\$ 250,831	\$ 29,169
Total Expenditures	<u>280,000</u>	<u>250,831</u>	<u>29,169</u>
Other Financing Sources			
Transfers In	300,000	300,000	-
Total Other Financings Sources	<u>300,000</u>	<u>300,000</u>	<u>-</u>
Net Change in Fund Balance	20,000	49,169	29,169
Cash Fund Balance - Beginning of Year	73,826	73,826	-
Cash Fund Balance - End of Year	<u>\$ 93,826</u>	<u>\$ 122,995</u>	<u>\$ 29,169</u>

City of Brook Park, Ohio

Schedule of Revenues, Expenditures and Changes in Fund Balance - Budget (Non-GAAP Budgetary Basis) and Actual

Continuing Training Program Fund

For The Year Ended December 31, 2019

	Budgeted Amounts		Variance with Final Budget Positive (Negative)
	<u>Final</u>	<u>Actual</u>	<u>(Negative)</u>
Expenditures:			
Current:			
Security of Persons and Property			
Operations	\$ 2,500	\$ -	\$ 2,500
Total Expenditures	<u>2,500</u>	<u>-</u>	<u>2,500</u>
 Net Change in Fund Balance	 (2,500)	 -	 2,500
 Cash Fund Balance - Beginning of Year	 23,233	 23,233	 -
Cash Fund Balance - End of Year	<u><u>\$ 20,733</u></u>	<u><u>\$ 23,233</u></u>	<u><u>\$ 2,500</u></u>

City of Brook Park, Ohio

Schedule of Revenues, Expenditures and Changes in Fund Balance -
 Budget (Non-GAAP Budgetary Basis) and Actual

FEMA Fund

For The Year Ended December 31, 2019

	Budgeted Amounts		Variance with Final Budget Positive (Negative)
	Final	Actual	
Cash Fund Balance - Beginning of Year	\$ 54,663	\$ 54,663	\$ -
Cash Fund Balance - End of Year	\$ 54,663	\$ 54,663	\$ -

City of Brook Park, Ohio

Schedule of Revenues, Expenditures and Changes in Fund Balance -
Budget (Non-GAAP Budgetary Basis) and Actual

Police Pension Fund

For The Year Ended December 31, 2019

	Budgeted Amounts		Variance with Final Budget Positive (Negative)
	Final	Actual	
Revenues:			
Property Taxes	\$ 121,461	\$ 121,461	\$ -
Intergovernmental	14,942	14,942	-
Total Revenues	<u>136,403</u>	<u>136,403</u>	<u>-</u>
Expenditures:			
Current:			
Security of Persons and Property			
Police and Others			
Personal Services	718,029	718,029	-
Total Expenditures	<u>718,029</u>	<u>718,029</u>	<u>-</u>
Excess of Revenues Over (Under) Expenditures	(581,626)	(581,626)	-
Other Financing Sources			
Transfers In	530,000	530,000	-
Total Other Financing Sources	<u>530,000</u>	<u>530,000</u>	<u>-</u>
Net Change in Fund Balance	(51,626)	(51,626)	-
Cash Fund Balance - Beginning of Year	84,464	84,464	-
Cash Fund Balance - End of Year	<u>\$ 32,838</u>	<u>\$ 32,838</u>	<u>\$ -</u>

City of Brook Park, Ohio

Schedule of Revenues, Expenditures and Changes in Fund Balance -
Budget (Non-GAAP Budgetary Basis) and Actual

Fire Pension Fund

For The Year Ended December 31, 2019

	Budgeted Amounts		Variance with Final Budget Positive (Negative)
	Final	Actual	
Revenues:			
Property Taxes	\$ 121,461	\$ 121,461	\$ -
Intergovernmental	14,942	14,942	-
Total Revenues	<u>136,403</u>	<u>136,403</u>	<u>-</u>
Expenditures:			
Current:			
Fire			
Personal Services	833,307	822,651	10,656
Total Expenditures	<u>833,307</u>	<u>822,651</u>	<u>10,656</u>
Excess of Revenues Over (Under) Expenditures	(696,904)	(686,248)	10,656
Other Financing Sources			
Transfers In	680,000	680,000	-
Total Other Financing Sources	<u>680,000</u>	<u>680,000</u>	<u>-</u>
Net Change in Fund Balance	(16,904)	(6,248)	10,656
Cash Fund Balance - Beginning of Year	44,420	44,420	-
Cash Fund Balance - End of Year	<u>\$ 27,516</u>	<u>\$ 38,172</u>	<u>\$ 10,656</u>

City of Brook Park, Ohio

Schedule of Revenues, Expenditures and Changes in Fund Balance -
Budget (Non-GAAP Budgetary Basis) and Actual

Southwest General Health Center Fund

For The Year Ended December 31, 2019

	Budgeted Amounts		Variance with Final Budget Positive (Negative)
	Final	Actual	
Revenues:			
Property Taxes	\$ 98,722	\$ 98,722	\$ -
Intergovernmental	12,800	12,800	-
Total Revenues	<u>111,522</u>	<u>111,522</u>	<u>-</u>
Expenditures:			
Current:			
Public Health and Welfare			
Operations	111,522	111,522	-
Total Expenditures	<u>111,522</u>	<u>111,522</u>	<u>-</u>
Net Change in Fund Balance	-	-	-
Cash Fund Balance - Beginning of Year	-	-	-
Cash Fund Balance - End of Year	<u>\$ -</u>	<u>\$ -</u>	<u>\$ -</u>

City of Brook Park, Ohio

Schedule of Revenues, Expenditures and Changes in Fund Balance - Budget (Non-GAAP Budgetary Basis) and Actual

Cash Bonds Held Fund

For The Year Ended December 31, 2019

	Budgeted Amounts Final	Actual	Variance with Final Budget Positive (Negative)
Revenues:			
Fees, Licenses, and Permits	\$ 21,680	\$ 21,680	\$ -
Total Revenues	<u>21,680</u>	<u>21,680</u>	<u>-</u>
Expenditures:			
Current:			
Community Environment Operations	96,689	1,000	95,689
Total Expenditures	<u>96,689</u>	<u>1,000</u>	<u>95,689</u>
Net Change in Fund Balance	(75,009)	20,680	95,689
Cash Fund Balance - Beginning of Year	441,361	76,009	(365,352)
Cash Fund Balance - End of Year	<u>\$ 366,352</u>	<u>\$ 96,689</u>	<u>\$ (269,663)</u>

City of Brook Park, Ohio

Schedule of Revenues, Expenditures and Changes in Fund Balance -
Budget (Non-GAAP Budgetary Basis) and Actual
General Obligation Fund

For The Year Ended December 31, 2019

	Budgeted Amounts		Variance with Final Budget Positive (Negative)
	Final	Actual	
Revenues:			
Intergovernmental	\$ 63,353	\$ 63,353	\$ -
Special Assessments	77,808	77,808	-
Total Revenues	<u>141,161</u>	<u>141,161</u>	<u>-</u>
Expenditures:			
Current:			
General Government			
Operations	5,769	4,519	1,250
Debt Service:			
Principal	745,830	745,830	-
Interest & Fiscal Charges	376,900	376,900	-
Total Debt Service	<u>1,122,730</u>	<u>1,122,730</u>	<u>-</u>
Total Expenditures	<u>1,128,499</u>	<u>1,127,249</u>	<u>1,250</u>
Excess of Revenues Over (Under) Expenditures	(987,338)	(986,088)	1,250
Other Financing Sources			
Transfers In	1,000,735	1,000,735	-
Total Other Financing Sources	<u>1,000,735</u>	<u>1,000,735</u>	<u>-</u>
Net Change in Fund Balance	13,397	14,647	1,250
Cash Fund Balance - Beginning of Year	1,323,732	1,323,732	-
Cash Fund Balance - End of Year	<u>\$ 1,337,129</u>	<u>\$ 1,338,379</u>	<u>\$ 1,250</u>

City of Brook Park, Ohio

Schedule of Revenues, Expenditures and Changes in Fund Equity-
Budget (Non-GAAP Budgetary Basis) and Actual

Self Insured Medical Benefits Fund

For The Year Ended December 31, 2019

	Budgeted Amounts		Variance with Final Budget Positive (Negative)
	Final	Actual	
Revenues:			
Charges for Services	\$ 1,948,059	\$ 1,948,059	\$ -
Total Revenues	<u>1,948,059</u>	<u>1,948,059</u>	<u>-</u>
Expenses			
Current:			
Personal Services	2,164,836	2,056,067	108,769
Total Expenses	<u>2,164,836</u>	<u>2,056,067</u>	<u>108,769</u>
Net Change in Fund Equity	(216,777)	(108,008)	108,769
Cash Fund Equity - Beginning of Year	3,057,606	3,057,606	-
Cash Fund Equity - End of Year	<u>\$ 2,840,829</u>	<u>\$ 2,949,598</u>	<u>\$ 108,769</u>

This page is intentionally left blank

STATISTICAL SECTION

City of Brook Park, Ohio

Statistical Section

This part of City's comprehensive annual financial report presents detailed information as a context for understanding what the information in the financial statements, note disclosures, and required supplementary information says about the City's overall financial health.

<u>Contents</u>	<u>Page(s)</u>
Financial Trends These schedules contain trend information to help the reader understand how the City's financial performance and well-being have changed over time.	S2 – S7
Revenue Capacity These schedules contain information to help the reader assess the City's most significant local revenue source, the property tax.	S8 - S13
Debt Capacity These schedules present information to help the reader assess the affordability of the City's current levels of outstanding debt and the City's ability to issue additional debt in the future.	S14–S17
Economic and Demographic Information These schedules offer economic and demographic indicators to help the reader understand the environment within which the City's financial activities take place.	S18-S19
Operating Information These schedules contain service data to help the reader understand how the information in the City's financial report relates to the services the City provides and the activities it performs.	S20-S23

Sources: Unless otherwise noted, the information in these schedules is derived from the comprehensive annual financial reports for the relevant year.

City of Brook Park, Ohio
Net Position by Component
Accrual Basis of Accounting
Last Ten Fiscal Years

Table 1

	2010	Restated (1) 2011	2012	2013	2014	Restated (2) 2015	2016	Restated (3) 2017	2018	2019
Governmental activities:										
Net investment in										
Capital assets	\$ 69,340,252	\$ 69,624,618	\$ 69,659,655	\$ 68,500,606	\$ 67,365,271	\$ 66,736,815	\$ 67,797,950	\$ 71,280,520	\$ 70,660,770	\$ 67,079,171
Restricted for:										
Capital projects	5,173,026	5,358,279	3,309,139	3,377,216	5,257,973	1,841,871	2,148,752	6,592,223	4,037,105	227,603
Debt service	651,203	634,751	730,029	747,956	803,224	3,994,770	3,726,530	1,162,932	1,370,897	1,337,446
Other purposes	501,409	615,393	1,180,925	1,257,622	1,270,567	1,156,438	219,890	298,572	347,549	205,957
Recreation	-	-	-	-	-	-	403,637	452,474	458,922	-
Public Safety	-	-	-	-	-	-	509,594	388,716	370,603	360,212
Economic development	507,980	357,863	456,696	449,730	304,469	1,263,245	800,811	250,866	417,541	-
Street paving and repair	1,402,084	1,527,587	1,646,532	1,778,891	2,023,577	2,441,997	2,284,811	1,552,700	1,815,900	2,404,362
Unrestricted	5,286,791	5,119,842	5,897,052	6,066,741	6,952,423	(7,673,180)	(7,147,730)	(28,253,077)	(29,332,329)	(13,580,960)
Total net position - governmental activities	<u>\$ 82,862,745</u>	<u>\$ 83,238,333</u>	<u>\$ 82,880,028</u>	<u>\$ 82,178,762</u>	<u>\$ 83,977,504</u>	<u>\$ 69,761,956</u>	<u>\$ 70,744,245</u>	<u>\$ 53,725,926</u>	<u>\$ 50,146,958</u>	<u>\$ 58,033,791</u>

(1) - Restatement done due to the implementation of GASB 65

(2) - Restatement done due to the implementation of GASB 68

(3) - Restatement done due to the implementation of GASB 75

Note: A portion of the 2019 net position was reclassified between restricted and unrestricted. This reclass did not affect the total 2019 net position.

City of Brook Park, Ohio
Changes in Net Position
Accrual Basis of Accounting
Last Ten Fiscal Years

Table 2

	2010	2011	2012	2013	2014	2015	2016	2017	2018	2019
Program revenues:										
Charges for services										
General government	\$ 551,319	\$ 565,523	\$ 578,665	\$ 824,690	\$ 694,869	\$ 796,582	\$ 658,301	\$ 898,000	\$ 763,062	\$ 811,501
Security of persons and property	1,262,634	922,977	991,409	721,429	1,257,395	1,225,940	1,315,914	1,197,804	1,117,801	1,126,189
Public health and welfare	20,622	18,294	16,413	16,966	5,229	190	220	130	310	400
Transportation	13,218	-	-	9,028	4,266	4,706	3,000	1,000	-	-
Leisure time activities	589,582	543,853	504,117	459,719	312,411	244,830	241,017	311,662	304,216	321,216
Community development	1,257,755	1,310,136	1,352,244	1,357,232	1,350,029	1,477,072	1,395,370	1,435,498	1,470,735	1,421,074
Public works	26,060	4,749	-	-	-	-	-	16,462	3,465	2,880
Total charges for services	<u>3,721,190</u>	<u>3,365,532</u>	<u>3,442,848</u>	<u>3,389,064</u>	<u>3,624,199</u>	<u>3,749,320</u>	<u>3,613,822</u>	<u>3,860,556</u>	<u>3,659,589</u>	<u>3,683,260</u>
Operating grants and contributions										
General government	9,000	7,035	58,103	10,292	21,137	37,576	27,842	-	-	-
Security of persons and property	35,846	16,893	12,899	119,180	48,522	98,194	77,796	33,690	18,795	17,895
Transportation	949,074	937,085	948,382	920,547	897,051	950,483	889,600	890,305	920,560	1,139,018
Leisure time activities	-	-	-	12,000	-	-	-	5,000	6,000	7,822
Community development	-	-	-	-	3,360	25,744	290,153	-	41,074	217,887
Public works	-	-	-	23,764	24,751	32,358	2,121	-	-	-
Total operating grants and contributions	<u>993,920</u>	<u>961,013</u>	<u>1,019,384</u>	<u>1,085,783</u>	<u>994,821</u>	<u>1,144,355</u>	<u>1,287,512</u>	<u>928,995</u>	<u>986,429</u>	<u>1,382,622</u>
Capital grants and contributions										
General government	-	185,500	-	-	1,420,975	58,288	-	30,140	-	-
Security of persons and property	3,000	117,755	7,968	-	-	-	-	-	112,602	-
Transportation	-	1,267,992	1,938,948	5,971	95,581	-	-	2,429,074	-	1,352,553
Leisure time activities	35,000	-	-	-	-	-	-	-	-	-
Community development	-	306,298	29,713	-	150,000	-	-	-	-	-
Public works	3,958,586	-	-	59,447	476,965	1,283,315	585,456	291,844	58,988	92,793
Total capital grants and contributions	<u>3,996,586</u>	<u>1,877,545</u>	<u>1,976,629</u>	<u>65,418</u>	<u>2,143,521</u>	<u>1,341,603</u>	<u>585,456</u>	<u>2,751,058</u>	<u>171,590</u>	<u>1,445,346</u>
Total program revenues	<u>8,711,696</u>	<u>6,204,090</u>	<u>6,438,861</u>	<u>4,540,265</u>	<u>6,762,541</u>	<u>6,235,278</u>	<u>5,486,790</u>	<u>7,540,609</u>	<u>4,817,608</u>	<u>6,511,228</u>

City of Brook Park, Ohio
Changes in Net Position (continued)
Accrual Basis of Accounting
Last Ten Fiscal Years

Table 2

	2010	2011	2012	2013	2014	2015	2016	2017	2018	2019
Expenses:										
General government	4,979,667	5,047,013	5,957,703	4,614,338	4,902,511	4,548,339	4,756,377	4,432,813	4,274,233	6,240,854
Security of persons and property	12,160,835	11,430,668	11,068,045	11,287,480	10,985,542	10,659,035	12,063,794	12,555,307	13,944,020	1,595,353
Public health and welfare	542,592	412,809	314,932	313,017	278,394	230,016	209,629	247,059	148,650	258,849
Transportation	2,613,821	2,486,308	3,213,847	3,083,726	3,210,908	3,081,564	2,946,070	3,610,372	4,656,162	6,004,889
Leisure time activities	2,581,318	2,562,792	2,305,024	2,198,184	2,095,119	1,508,908	1,567,408	1,752,451	3,144,157	3,331,253
Community development	1,790,631	1,428,069	1,035,202	886,092	1,088,706	1,160,879	1,637,055	1,371,587	1,264,341	1,639,970
Public works	3,537,459	3,547,146	3,501,691	3,230,274	3,218,651	3,080,342	3,228,252	4,130,367	3,141,480	3,537,867
Interest and fiscal charges	44,829	46,100	98,982	264,510	284,964	230,077	238,212	512,537	394,353	365,537
Total primary government expenses	<u>28,251,152</u>	<u>26,960,905</u>	<u>27,495,426</u>	<u>25,877,621</u>	<u>26,064,795</u>	<u>24,499,160</u>	<u>26,646,797</u>	<u>28,612,493</u>	<u>30,967,396</u>	<u>22,974,572</u>
Net (expense)/revenue	<u>(19,539,456)</u>	<u>(20,756,815)</u>	<u>(21,056,565)</u>	<u>(21,337,356)</u>	<u>(19,302,254)</u>	<u>(18,263,882)</u>	<u>(21,160,007)</u>	<u>(21,071,884)</u>	<u>(26,149,788)</u>	<u>(16,463,344)</u>
General revenues										
Property taxes	2,026,186	1,994,242	1,986,778	1,807,889	1,684,574	1,769,793	1,836,353	1,852,018	1,840,585	2,045,673
Municipal income taxes and Other Taxes	17,029,564	17,801,257	17,768,862	18,134,634	18,556,361	19,570,562	19,608,280	19,774,881	19,911,095	21,231,634
Grants and entitlements										
not restricted to specific programs	2,016,732	1,393,561	878,135	615,425	790,071	716,253	618,590	600,624	596,775	713,811
Investment income	29,733	4,702	7,157	2,045	4,746	19,345	62,985	112,037	188,782	204,679
All other revenues	4,603	2,428	57,328	76,097	65,244	1,265	16,088	24,845	33,583	154,380
Total general revenues	<u>21,106,818</u>	<u>21,196,190</u>	<u>20,698,260</u>	<u>20,636,090</u>	<u>21,100,996</u>	<u>22,077,218</u>	<u>22,142,296</u>	<u>22,364,405</u>	<u>22,570,820</u>	<u>24,350,177</u>
Change in net position	<u>\$ 1,567,362</u>	<u>\$ 439,375</u>	<u>\$ (358,305)</u>	<u>\$ (701,266)</u>	<u>\$ 1,798,742</u>	<u>\$ 3,813,336</u>	<u>\$ 982,289</u>	<u>\$ 1,292,521</u>	<u>\$ (3,578,968)</u>	<u>\$ 7,886,833</u>

City of Brook Park, Ohio
Fund Balances, Governmental Funds
Modified Accrual Basis of Accounting
Last Ten Fiscal Years

Table 3

	2010	2011	2012	2013	2014	2015	2016	2017	2018	2019
General fund:										
Nonspendable	\$ 370,218	\$ 283,312	\$ 266,001	\$ 261,923	\$ 273,738	\$ 295,958	\$ 333,786	\$ 236,118	\$ 586,826	\$ 601,747
Committed	3,763,449	3,229,970	2,767,778	1,874,885	1,481,623	1,661,168	1,987,936	2,251,239	2,625,460	2,991,010
Assigned	1,109,427	414,414	277,395	266,035	250,794	216,578	2,639,376	404,642	1,457,142	2,319,089
Unassigned	684,449	1,415,476	3,064,486	3,070,287	3,375,377	6,697,552	4,787,899	6,028,519	6,109,471	6,980,856
Total general fund	<u>5,927,543</u>	<u>5,343,172</u>	<u>6,375,660</u>	<u>5,473,130</u>	<u>5,381,532</u>	<u>8,871,256</u>	<u>9,748,997</u>	<u>8,920,518</u>	<u>10,778,899</u>	<u>12,892,702</u>
All other governmental funds:										
Nonspendable	-	-	-	-	-	-	-	392	-	-
Restricted	3,793,076	4,316,404	3,980,814	6,967,254	6,231,265	5,247,066	4,026,978	5,307,204	2,989,931	3,507,077
Committed	3,747,047	3,568,496	2,246,761	4,091,320	4,055,013	3,957,344	4,336,381	4,452,527	4,545,380	4,464,332
Assigned	2,669,474	2,639,466	1,757,135	859,276	891,596	891,596	1,128,496	1,105,049	1,313,686	1,309,936
Unassigned (Deficit)	(455,619)	(445,746)	(354,414)	(102,722)	(153,258)	(27,198)	(66,984)	-	(14,709)	-
Total all other governmental funds	<u>9,753,978</u>	<u>10,078,620</u>	<u>7,630,296</u>	<u>11,815,128</u>	<u>11,024,616</u>	<u>10,068,808</u>	<u>9,424,871</u>	<u>10,865,172</u>	<u>8,834,288</u>	<u>9,281,345</u>
Total governmental funds	<u>\$ 15,681,521</u>	<u>\$ 15,421,792</u>	<u>\$ 14,005,956</u>	<u>\$ 17,288,258</u>	<u>\$ 16,406,148</u>	<u>\$ 18,940,064</u>	<u>\$ 19,173,868</u>	<u>\$ 19,785,690</u>	<u>\$ 19,613,187</u>	<u>\$ 22,174,047</u>

City of Brook Park, Ohio

Changes in Fund Balances, Governmental Funds

Modified Accrual Basis of Accounting

Last Ten Fiscal Years

Table 4

	2010	2011	2012	2013	2014	2015	2016	2017	2018	2019
Revenues:										
Property Taxes	\$ 2,031,983	\$ 2,002,050	\$ 1,952,842	\$ 1,827,212	\$ 1,735,105	\$ 1,777,005	\$ 1,832,246	\$ 1,854,778	\$ 1,842,191	\$ 2,044,841
Income Taxes	16,959,103	17,465,889	17,603,699	17,577,172	18,097,977	19,271,134	19,055,491	19,436,285	19,794,513	20,547,833
Other Taxes	271,452	325,486	213,567	338,001	345,238	344,687	375,180	294,893	354,703	418,621
Intergovernmental	6,508,356	3,772,270	3,537,753	1,861,096	3,952,536	2,969,726	2,177,933	4,243,934	1,593,681	3,580,345
Interest	33,181	4,893	7,172	2,045	4,746	19,345	62,985	112,067	188,782	204,679
Licenses and Permits	547,492	705,694	689,562	739,328	699,901	855,440	751,259	642,082	693,099	769,317
Fines and Forfeitures	531,713	350,017	408,470	268,370	535,859	851,371	715,504	707,177	529,567	666,224
Rentals	2,500	1,975	3,550	3,850	1,650	87,998	90,176	53,299	50,090	50,165
Charges for Services	2,360,691	1,984,816	1,867,450	1,785,589	1,773,668	1,688,949	1,662,569	1,763,713	2,352,928	2,223,894
Contributions and Donations	15,208	219,725	190,820	91,648	72,075	35,724	38,735	1,825	5,215	6,369
Special Assessments	82,933	85,071	85,066	85,512	82,455	82,987	63,354	60,216	40,652	77,808
All Other Revenues	478,617	700,243	471,719	722,235	443,236	472,446	676,328	646,469	30,229	150,834
Total Revenues	29,823,229	27,618,129	27,031,670	25,302,058	27,744,446	28,456,812	27,501,760	29,816,738	27,475,650	30,740,930
Expenditures:										
Current:										
Security of persons and property	11,588,747	11,540,053	11,014,188	11,017,683	10,799,690	10,162,731	10,775,343	11,049,682	11,221,844	11,807,686
Public health and welfare	433,317	408,973	309,741	307,431	272,808	218,934	203,908	234,788	140,349	245,871
Leisure time activities	2,176,888	2,243,478	2,031,832	1,878,129	1,841,553	1,196,974	1,264,030	1,266,269	1,296,096	1,325,445
Community development	1,168,046	1,942,284	1,037,516	895,478	1,372,890	1,149,580	1,673,383	1,218,055	1,187,445	1,349,657
Public works	2,942,100	3,052,788	2,820,750	2,456,099	2,795,928	2,275,222	2,492,120	2,391,617	1,727,642	2,082,317
Transportation	1,560,812	1,643,494	4,243,551	2,427,129	1,250,950	1,212,767	1,310,713	1,903,259	2,391,326	2,109,374
General government	4,826,362	4,791,064	5,556,723	6,957,185	5,589,126	4,546,852	4,624,175	3,747,761	3,717,179	3,804,306
Capital Outlay	5,420,568	3,648,548	2,968,253	1,270,804	3,985,506	5,578,459	4,146,644	12,707,301	4,139,254	4,482,252
Debt Service:										
Principal retirement	228,733	287,467	388,374	398,374	608,374	764,579	541,847	1,372,623	1,469,126	1,227,395
Interest and fiscal charges	53,477	48,075	90,704	84,467	314,141	282,883	257,212	350,414	428,968	399,714
Bond issuance costs	-	64,143	2,491	115,166	-	-	-	160,098	-	-
Total expenditures	30,399,050	29,670,367	30,464,123	27,807,945	28,830,966	27,388,981	27,289,375	36,401,867	27,719,229	28,834,017
Excess of revenues over (under) expenditures	(575,821)	(2,052,238)	(3,432,453)	(2,505,887)	(1,086,520)	1,067,831	212,385	(6,585,129)	(243,579)	1,906,913

City of Brook Park, Ohio

Changes in Fund Balances, Governmental Funds (continued)

Modified Accrual Basis of Accounting

Last Ten Fiscal Years

Table 4

	2010	2011	2012	2013	2014	2015	2016	2017	2018	2019
Other financing sources (uses):										
General Obligation Bond issued	-	1,705,000	-	5,520,000	-	-	-	4,980,000	-	-
OPWC loans issued	92,896	25,243	-	-	-	1,429,520	19,611	-	-	106,689
Premium on Debt issuance	-	25,873	-	253,973	-	-	-	219,628	-	-
Capital leases	-	-	2,006,371	-	150,879	-	-	1,997,323	-	-
Sale of capital assets	8,660	36,393	10,246	14,216	53,531	36,565	1,808	-	71,076	547,258
Transfers in	3,423,113	1,390,040	3,534,965	2,817,504	2,010,532	3,726,485	3,757,891	5,227,068	3,399,560	4,024,323
Transfers out	(3,423,113)	(1,390,040)	(3,534,965)	(2,817,504)	(2,010,532)	(3,726,485)	(3,757,891)	(5,227,068)	(3,399,560)	(4,024,323)
Total other financing sources (uses)	101,556	1,792,509	2,016,617	5,788,189	204,410	1,466,085	21,419	7,196,951	71,076	653,947
Net change in fund balances	\$ (474,265)	\$ (259,729)	\$ (1,415,836)	\$ 3,282,302	\$ (882,110)	\$ 2,533,916	\$ 233,804	\$ 611,822	\$ (172,503)	\$ 2,560,860
Debt service as a percentage of noncapital expenditures	1.11%	1.29%	1.88%	1.97%	3.73%	4.77%	3.39%	6.48%	7.65%	6.14%

City of Brook Park, Ohio

Assessed Valuations and Estimated True Values

Last Ten Fiscal Years

Table 5

Collection Year	Real Property			Tangible Personal Property		Total		Ratio	Direct Tax Rate
	Assessed Value		Estimated Actual Value	Assessed Value Public Utility	Estimated Actual Value	Assessed Value	Estimated Actual Value		
	Residential/Agricultural	Commercial Industrial/PU							
2010	290,810,300	148,270,160	\$1,254,515,600	9,019,390	\$10,249,307	448,099,850	\$1,264,764,907	35.43%	4.75
2011	291,898,930	171,886,210	1,325,100,400	9,310,360	10,579,955	473,095,500	1,335,680,355	35.42	4.75
2012	291,695,680	171,577,480	1,323,637,600	9,584,670	10,891,670	472,857,830	1,334,529,270	35.43	4.75
2013	256,589,630	153,158,610	1,170,709,257	10,334,750	11,744,034	420,082,990	1,182,453,291	35.53	4.75
2014	256,527,620	153,604,430	1,171,805,857	11,308,840	12,850,955	421,440,890	1,184,656,812	35.57	4.75
2015	256,334,940	149,203,660	1,158,681,714	11,718,840	13,316,864	417,257,440	1,171,998,578	35.60	4.75
2016	250,842,440	146,587,480	1,135,514,057	11,850,930	13,466,966	409,280,850	1,148,981,023	35.62	4.75
2017	250,821,870	147,770,180	1,138,834,429	12,450,870	14,148,716	411,042,920	1,152,983,144	35.65	4.75
2018	250,684,950	150,127,270	1,145,177,771	13,387,250	15,212,784	414,199,470	1,160,390,556	35.69	4.75
2019	280,925,310	156,441,670	1,249,619,943	13,748,880	15,623,727	451,115,860	1,265,243,670	35.65	4.75

Real property is reappraised every six years with a State mandated update of the current market value in the third year following each reappraisal.

The assessed value of real property (including public utility real property) is 35 percent of estimated true value. The assessed value of public utility personal property ranges from 25 percent of true value for railroad property to 88 percent for electric transmission and distribution property. General business tangible personal property was assessed in previous years at 25 percent for machinery and equipment and 23 percent for inventories.

Source: Cuyahoga County Fiscal Office

City of Brook Park, Ohio

Property Tax Rates – Direct and Overlapping Governments (Per \$1,000 of Assessed Valuation)

Last Ten Years

Table 6

Collection Year	City of Brook Park			Berea City School District	Polaris Vocational School	Cuyahoga County Commissioners	Special (1) Taxing Districts	Total Tax Levy
	General Fund	Special Funds	Total Levy					
2010	3.85	0.90	4.75	74.90	2.40	13.32	7.58	102.95
2011	3.85	0.90	4.75	75.00	2.40	13.22	7.58	102.95
2012	3.85	0.90	4.75	78.90	2.40	13.22	7.58	106.85
2013	3.85	0.90	4.75	78.90	2.40	13.22	7.58	106.85
2014	3.85	0.90	4.75	78.80	2.40	14.05	8.48	108.48
2015	3.85	0.90	4.75	78.00	2.40	14.05	9.38	108.58
2016	3.85	0.90	4.75	82.20	3.09	14.05	9.38	113.47
2017	3.85	0.90	4.75	82.20	3.09	14.05	9.88	113.97
2018	3.85	0.90	4.75	82.20	3.09	14.05	9.88	113.97
2019	3.85	0.90	4.75	82.20	3.09	14.05	9.88	113.97

Source: Cuyahoga County Fiscal Officer

(1) – Metroparks, Port Authority, County Library, Community College

City of Brook Park, Ohio
Real Property Tax Levies And Collections
Last Ten Years

Table 7a

<u>Year</u>	<u>Current Tax Levy</u>	<u>Current Collections</u>	<u>Percentage of Current Collections To Current Levy</u>	<u>Prior Year Collections</u>	<u>Total Collections (1)</u>	<u>Percentage of Total Collections To Current Levy</u>
2010	2,199,507	2,134,591	97%	65,000	2,199,591	100%
2011	2,219,407	2,114,938	95%	71,669	2,186,607	99%
2012	2,225,730	2,072,366	93%	73,996	2,146,362	96%
2013	1,998,706	1,908,141	95%	59,236	1,967,377	98%
2014	1,985,143	1,802,931	91%	66,265	1,869,196	94%
2015	1,968,424	1,847,043	94%	31,346	1,878,389	95%
2016	1,937,631	1,840,233	95%	45,838	1,886,071	97%
2017	1,960,980	1,905,677	97%	50,368	1,956,045	100%
2018	1,965,013	1,913,522	97%	48,507	1,962,029	100%
2019	2,121,392	2,077,312	98%	57,431	2,134,743	101%

Source: Cuyahoga County Fiscal Officer

(1) State reimbursement of rollback and homestead exemptions is included

Note: The County is aware of the requirement to report delinquent tax collections by levy year rather than by collection year. The County's current computer system tracks levy amounts by either current levy or delinquent levy. Once amounts become part of the delinquent levy, the ability to track information by levy year is lost. The County is looking at options to provide this information in the future.

City of Brook Park, Ohio

Tangible Personal Property Tax Levies And Collections

Last Ten Years

Table 7b

<u>Year</u>	<u>Current Tax Levy</u>	<u>Current Collections</u>	<u>Percentage of Current Collections To Current Levy</u>	<u>Prior Year Collections</u>	<u>Total Collections</u>	<u>Percentage of Total Collections To Current Levy</u>
2010	3,070	3,070	100%	-	3,070	100%
2011	-	-	0%	984	984	0%
2012	-	-	0%	152	152	0%
2013	-	-	0%	67	67	0%
2014	-	-	0%	-	-	0%
2015	-	-	0%	-	-	0%
2016	-	-	0%	-	-	0%
2017	-	-	0%	-	-	0%
2018	-	-	0%	-	-	0%
2019	-	-	0%	-	-	0%

Source: Cuyahoga County Fiscal Officer

Note: In 2010, tangible personal property taxes were completely phased out. Therefore, this tax will no longer be levied. Refer to the Note provided in Table 7a which provides an explanation for the percentages of total collections exceeding the current levies.

City of Brook Park, Ohio
Principal Taxpayers - Real Estate Tax
2019 and 2010

Table 8

Name of Taxpayer	December 31, 2019	
	Assessed Value (1) (2)	Percent of Total Assessed Value
Cleveland Electric Illum Co	\$ 10,316,450	2.36%
Deep Discount Properties LLC	10,062,020	2.30%
CP-Snow Prop, LLC	5,986,900	1.37%
Ford Motor Engine Plt.	5,311,250	1.21%
Laich, Walter	4,662,000	1.07%
Brook Park Station, LLC	3,541,690	0.81%
Cleveland ADC, LLC	3,275,830	0.75%
Ford Motor CO.	3,001,430	0.69%
Techpark Ltd Partnership	3,316,090	0.76%
Total	<u>\$ 49,473,660</u>	<u>11.32%</u>
Total Assessed Valuation	<u>437,366,980</u>	

Name of Taxpayer	December 31, 2010	
	Assessed Value (1) (2)	Percent of Total Assessed Value
Ford Motor Company	\$ 20,055,470	4.57%
M.W.P. Company	11,162,230	2.54%
Cleveland Electric Illuminating	8,181,700	1.86%
Tech Park Limited Partnership	8,000,500	1.82%
Laich, Walter	6,345,510	1.45%
Albrecht Inc.	5,372,590	1.22%
CP-Snow Prop, LLC	5,207,690	1.19%
Brookgate Associates, LLC	4,705,330	1.07%
CP-Cleveland ADC, LLC	4,237,050	0.96%
Foseco Metallurgical Inc.	2,245,810	0.51%
Total	<u>\$ 75,513,880</u>	<u>17.19%</u>
Total Assessed Valuation	<u>439,080,460</u>	

Source: Cuyahoga County Fiscal Officer
(1) Excludes Public Utilities
(2) The amounts presented represent the assessed values upon which 2019 collections were based.

City of Brook Park, Ohio

Municipal Income Tax Revenues By Source

Modified Accrual Basis of Accounting

Last Ten Years

Table 9

<u>Withheld Year</u>	<u>Individual Tax</u>	<u>Municipal Direct Tax</u>	<u>Business Direct Tax</u>	<u>Income Tax Collections</u>
2010	14,904,762	610,161	1,444,180	16,959,103
2011	15,407,196	754,473	1,304,220	17,465,889
2012	15,348,105	681,180	1,574,414	17,603,699
2013	15,290,038	708,829	1,578,305	17,577,172
2014	15,607,541	693,255	1,797,181	18,097,977
2015	16,689,291	861,607	1,720,236	19,271,134
2016	16,601,871	854,375	1,599,245	19,055,491
2017	16,751,040	871,010	1,857,938	19,479,988
2018	17,125,289	886,236	1,544,868	19,556,393
2019	17,811,207	876,837	2,124,969	20,813,013

Source: City Financial Records

City of Brook Park, Ohio

Ratio of Outstanding Debt to Total Personal Income and Debt per Capita

Last Ten Years

Table 10

Fiscal Year	Governmental Activities					Total	Percentage of Personal Income	Per Capita
	General Obligation Bonds (1)	General Obligation Notes (1)	OPWC Loans	OWDA Loan	Lease Purchase Agreements			
2010	1,250,000	-	1,993,495	-	222,556	3,466,051	0.75%	180
2011	2,765,000	-	1,921,271	-	2,403	4,688,674	1.02%	244
2012	2,480,000	750,000	1,817,897	-	1,616,919	6,664,816	1.45%	347
2013	7,977,641	-	1,714,523	-	1,253,966	10,946,130	2.38%	570
2014	7,456,470	-	1,611,149	-	984,644	10,052,263	2.19%	523
2015	7,060,299	-	2,921,137	-	719,597	10,701,033	2.33%	557
2016	6,654,127	-	2,788,901	-	449,965	9,892,993	2.15%	515
2017	11,340,263	-	2,633,141	-	1,720,425	15,693,829	3.41%	817
2018	10,718,111	-	2,457,310	-	1,022,130	14,197,551	3.09%	739
2019	10,120,959	-	2,388,169	-	540,565	13,049,693	2.84%	679

(1) – Amounts include associated premiums

Source: City Financial Records

- Population and Personal Income data are presented on Table 15
- The OPWC Loans are in the City's name; however, \$633,534 of the total outstanding at December 31, 2019 will be reimbursed by the City of Cleveland.

City of Brook Park, Ohio

Ratio of Net General Bonded Debt to Assessed Value and Net Bonded Debt Per Capita

Last Ten Years

Table 11

<u>Year</u>	<u>Gross Bonded Debt (1)</u>	<u>Accumulated Resources Restricted For Repayment</u>	<u>Net General Bonded Debt</u>	<u>Assessed Value (3)</u>	<u>Population (2)</u>	<u>Ratio of Net Bonded Debt to Assessed Value</u>	<u>Debt per Capita</u>
2010	1,250,000	(651,203)	598,797	448,099,850	19,212	0.13%	31.17
2011	2,765,000	(634,751)	2,130,249	473,095,500	19,212	0.45%	110.88
2012	2,480,000	(730,029)	1,749,971	472,857,830	19,212	0.37%	91.09
2013	7,977,641	(747,956)	7,229,685	420,082,990	19,212	1.72%	376.31
2014	7,456,470	(803,224)	6,653,246	421,440,890	19,212	1.58%	346.31
2015	7,060,299	(3,994,770)	3,065,529	417,257,440	19,212	0.73%	159.56
2016	6,654,127	(3,726,530)	2,927,597	409,280,850	19,212	0.72%	152.38
2017	11,340,263	(1,162,932)	10,177,331	411,042,920	19,212	2.48%	529.74
2018	10,718,111	(1,370,897)	9,347,214	414,199,470	19,212	2.26%	486.53
2019	10,120,959	(1,337,446)	8,783,513	451,115,860	19,212	1.95%	457.19

(1) Includes all general obligation bonded debt and unamortized premiums.

(2) Source: 2010 U.S. Census

(3) Office of the County Fiscal Officer, Cuyahoga County, Ohio

City of Brook Park, Ohio

Computation of Direct and Overlapping Debt
December 31, 2019

Table 12

<u>Jurisdiction</u>	<u>Net Debt Outstanding</u>	(1) <u>Percentage Applicable to City of Brook Park</u>	<u>Amount Applicable to City of Brook Park</u>
Direct Debt:			
City of Brook Park (2)			
General Obligation Bonds	\$ 10,120,959	100.00%	\$ 10,120,959
OPWC Loan	2,388,169	100.00%	2,388,169
Capital Leases	540,565	100.00%	540,565
Total Direct Debt	<u>13,049,693</u>		<u>13,049,693</u>
Overlapping Debt:			
Berea City School District	109,553,000	29.54%	32,361,969
Cleveland City School District	231,922,059	0.46%	1,056,460
Cuyahoga County	245,120,000	1.64%	4,012,897
Cuyahoga Community College	207,010,000	1.64%	3,388,992
Total Overlapping Debt	<u>793,605,059</u>		<u>40,820,318</u>
Total	<u>\$ 806,654,752</u>		<u>\$ 53,870,011</u>

Source: Cuyahoga County Fiscal Officer

- (1) Percentages determined by dividing each overlapping subdivision's assessed valuation within the City by the subdivision's total assessed valuation.
- (2) Amounts include associated premiums.

City of Brook Park, Ohio

Legal Debt Margin

Last Ten Fiscal Years

Table 13

	2010	2011	2012	2013	2014	2015	2016	2017	2018	2019
Assessed Valuation	\$ 448,099,850	\$ 473,095,500	\$ 472,857,830	\$ 420,082,990	\$ 421,440,890	\$ 417,257,440	\$ 409,280,850	\$ 411,042,920	\$ 414,199,470	\$ 451,115,860
Overall debt limit - 10.5% of assessed value	47,050,484	49,675,028	49,650,072	44,108,714	44,251,293	43,812,031	42,974,489	43,159,507	43,490,944	47,367,165
Gross indebtedness	3,466,051	4,686,271	5,047,897	9,692,164	9,067,619	9,981,436	9,443,028	13,973,404	13,175,421	12,509,128
Less: debt outside limitation	(1,235,389)	(1,140,359)	(1,077,005)	(1,013,652)	(950,299)	(886,946)	(823,593)	(760,240)	(696,887)	(633,534)
Less: amount available in debt service fund	(1,802,168)	(1,757,346)	(1,725,522)	(1,901,974)	(1,872,159)	(1,805,318)	(2,111,431)	(1,895,640)	(2,020,619)	(1,971,913)
Net debt within 10.5% limit	428,494	1,788,566	2,245,370	6,776,538	6,245,161	7,289,172	6,508,004	11,317,524	10,457,915	9,903,681
Legal Debt Margin	\$ 46,621,990	\$ 47,886,462	\$ 47,404,702	\$ 37,332,176	\$ 38,006,132	\$ 36,522,859	\$ 36,466,485	\$ 31,841,983	\$ 33,033,029	\$ 37,463,484
Debt Limit - 5.5% of assessed unvoted value	\$ 24,645,492	\$ 26,020,253	\$ 26,007,181	\$ 23,104,564	\$ 23,179,249	\$ 22,949,159	\$ 22,510,447	\$ 22,607,361	22,780,971	24,811,372
Gross indebtedness authorized by council:	3,466,051	4,686,271	4,686,271	9,692,164	9,067,619	9,981,436	9,443,028	13,973,404	13,175,421	12,509,128
Less: debt outside limitation	(1,235,389)	(1,140,359)	(1,077,005)	(1,013,652)	(950,299)	(886,946)	(823,593)	(760,240)	(696,887)	(633,534)
Less: amount available in debt service fund	(1,802,168)	(1,757,346)	(1,725,522)	(1,901,974)	(1,872,159)	(1,805,318)	(2,111,431)	(1,895,640)	(2,020,619)	(1,971,913)
Net debt within 5.5% limit	428,494	1,788,566	1,883,744	6,776,538	6,245,161	7,289,172	6,508,004	11,317,524	10,457,915	9,903,681
Unvoted debt margin	\$ 24,216,998	\$ 24,231,687	\$ 24,123,437	\$ 16,328,026	\$ 16,934,088	\$ 15,659,987	\$ 16,002,443	\$ 11,289,837	\$ 12,323,056	\$ 14,907,691

Source: Cuyahoga County Fiscal Officer and City Financial Records

City of Brook Park, Ohio

Principal Employers

Current Year and 2010

Table 14

<u>Employer</u>	2019	
	<u>Employees</u>	<u>Percentage of</u>
Ford Motor Company	1,926	8.23%
Department of the Interior	1,662	7.10%
Marc Glassman Inc.	676	2.89%
DSS Holdings	557	2.38%
Minute Men Temps	406	1.73%
Group Management	300	1.28%
Credit First National	283	1.21%
Global Payment Holding	279	1.19%
City of Brook Park	275	1.17%
Alycon Technical	250	1.07%
Total	<u>6,614</u>	<u>28.25%</u>
Total City Employment	<u>23,407</u>	<u>100.00%</u>

<u>Employer</u>	2010	
	<u>Employees</u>	<u>Percentage of</u>
Department of the Interior	1,730	8.41%
Ford Motor Company	1,298	6.31%
Marc Glassman Inc.	558	2.71%
PNC Bank	406	1.97%
City of Brook Park	351	1.71%
Berea City School District	313	1.52%
Ohio Aerospace Institute	303	1.47%
Credit First National	251	1.22%
Lakefront Lines, Inc.	234	1.14%
Vesuvius USA Corp.	218	1.06%
Total	<u>5,662</u>	<u>27.54%</u>
Total City Employment	<u>20,560</u>	<u>100.00%</u>

Source: City Income Tax Department.

City of Brook Park, Ohio
Demographic and Economic Statistics
Last Ten Years

Table 15

<u>Year</u>	<u>Population (1)</u>	<u>Total Personal Income (4)</u>	<u>Personal Income Per Capita (1)</u>	<u>Median Household Income (1)</u>	<u>Median Age (1)</u>	<u>School Enrollment (2)</u>	<u>Cuyahoga County Unemployment Rate (3)</u>
2010	19,212	459,704,736	23,928	53,264	43.8	7,099	9.5%
2011	19,212	459,704,736	23,928	53,264	43.8	7,017	7.1%
2012	19,212	459,704,736	23,928	53,264	43.8	7,122	6.6%
2013	19,212	459,704,736	23,928	53,264	43.8	6,681	7.2%
2014	19,212	459,704,736	23,928	53,264	43.8	6,361	5.3%
2015	19,212	459,704,736	23,928	53,264	43.8	6,491	5.5%
2016	19,212	459,704,736	23,928	53,264	43.8	6,537	5.5%
2017	19,212	459,704,736	23,928	53,264	43.8	6,379	5.6%
2018	19,212	459,704,736	23,928	53,264	43.8	6,064	5.0%
2019	19,212	459,704,736	23,928	53,264	43.8	5,817	3.6%

(1) Source: 2010 U. S. Census

(2) Source: Ohio Department of Education Website

(3) Source: Ohio Bureau of Employment Services, U.S. Department of Labor, Bureau of Labor Statistics for Cleveland

(4) Computation of per capita personal income multiplied by population

City of Brook Park, Ohio
Full Time Employees by Function/Program
Last Ten Years

Table 16

	2010	2011	2012	2013	2014	2015	2016	2017	2018	2019
Function/program:										
General government:										
Council	2.00	2.00	1.50	1.00	1.00	1.00	1.00	1.00	1.00	1.00
Finance	4.00	4.00	4.00	4.00	4.00	4.00	4.00	4.00	5.00	5.00
Tax	4.00	3.00	3.50	3.00	3.00	3.00	3.00	3.00	3.00	3.00
Law	2.00	1.00	1.50	1.00	1.00	1.00	1.00	2.00	2.00	2.00
Mayor's office	2.00	2.00	2.00	3.00	2.00	2.00	3.00	3.00	3.50	3.50
Human resources	1.00	1.00	1.00	1.00	1.00	1.00	1.00	1.00	1.00	1.00
Civil service	0.50	-	0.50	-	0.50	0.50	0.50	0.50	0.50	0.50
Clerk of courts	1.00	1.00	1.00	1.00	1.00	1.00	1.00	1.00	1.00	1.00
Security of persons and property:										
Safety department	11.00	9.00	9.00	11.00	8.00	6.00	6.00	3.00	3.00	3.00
Animal warden	1.00	1.00	1.50	1.00	1.50	1.50	1.50	1.50	1.50	1.50
Police	43.00	39.00	39.00	41.00	38.00	36.00	36.00	36.00	35.00	34.00
Police administration	1.00	1.00	1.00	1.00	1.00	1.00	1.00	1.00	2.00	2.00
Property maintenance	4.00	4.00	3.00	4.00	4.00	3.00	3.00	4.00	4.00	4.00
Fire	37.00	34.00	34.00	36.00	33.00	30.00	30.00	30.00	30.00	31.00
Fire administration	1.00	1.00	-	-	-	-	-	-	1.00	1.00
Public health and welfare:										
Office of aging	2.50	2.50	1.50	-	-	-	-	-	1.50	1.50
Leisure time activities:										
Recreation	7.50	7.00	6.00	6.00	7.00	6.00	5.00	5.00	5.00	5.00
Community development:										
Building	6.00	5.00	4.00	4.00	5.00	5.00	5.00	5.50	5.00	5.00
Economic development	1.00	1.00	1.00	1.00	1.00	1.00	1.00	1.00	1.00	1.00
Transportation:										
Service	43.50	43.00	40.50	36.00	39.00	31.00	36.00	36.00	33.00	30.00
Public works:										
Service	5.00	4.00	3.00	3.00	1.00	1.00	1.00	1.00	1.00	1.00
Service dispatch	1.00	1.00	1.00	1.00	1.00	1.00	1.00	1.00	1.00	1.00
Totals	<u>181.00</u>	<u>166.50</u>	<u>159.50</u>	<u>159.00</u>	<u>153.00</u>	<u>136.00</u>	<u>141.00</u>	<u>140.50</u>	<u>141.00</u>	<u>138.00</u>

Source: City Payroll Records

City of Brook Park, Ohio
Operating Indicators by Function/Program
Last Ten Years

Table 17

	2010	2011	2012	2013	2014	2015	2016	2017	2018	2019
Function/program:										
General government:										
Council and clerk										
Number of ordinances passed	55	66	60	55	75	44	67	40	43	81
Number of resolutions passed	21	27	40	27	24	26	37	29	39	39
Finance department:										
Number of checks/vouchers issued (excluding payroll)	5,115	5,016	4,877	4,444	4,260	3,893	3,617	3,282	3,124	3,031
Number of purchase orders issued	1,349	1,344	1,320	1,226	1,151	1,035	1,037	995	966	909
Number of W-2 forms issued	351	335	348	377	374	322	302	276	272	279
City W-2 wages (in millions)	14	13	13	12	12	12	11	12	12	12
Agency ratings - Fitch	AA	AA	AA	AA-	AA-	AA-	AA-	AA-	AA-	AA-
Income tax department:										
Number of individual returns	10,572	10,379	10,022	9,970	9,984	10,085	10,473	10,398	10,358	10,126
Number of business returns	1,668	1,659	1,758	1,779	1,810	1,922	1,820	1,800	1,800	1,867
Number of business withholding accounts	1,591	1,476	1,552	1,480	1,554	1,568	1,553	1,581	1,604	1,600
Civil service:										
Number of exams given	2	6	4	5	2	1	2	1	3	4
Building department										
Number of permits issued	1,439	1,401	1,330	1,408	1,392	1,510	1,309	1,314	1,320	1,381
Security of persons and property:										
Police:										
Number of traffic citations issued	2,853	2,203	2,389	2,338	4,900	7,959	5,886	6,258	3,766	4,954
Number of parking citations issued	2,125	2,197	2,412	1,619	1,850	2,279	2,257	2,479	2,335	2,710
Number of criminal arrests	814	1,078	928	731	684	707	487	646	537	463
Animal warden service calls responded to per annual report	187	129	768	1,209	1,171	1,095	1,177	1,244	1,326	1,408

City of Brook Park, Ohio

Operating Indicators by Function/Program (continued)

Last Ten Years

Table 17

	2010	2011	2012	2013	2014	2015	2016	2017	2018	2019
Security of persons and property:										
Fire:										
EMS calls	2,190	2,282	2,447	2,204	2,549	2,572	2,639	2,901	2,573	2,747
Fire and fire-related calls	418	411	449	423	429	446	440	576	607	646
Hydrants tested	1,250	1,250	1,250	1,250	1,149	1,206	1,206	1,206	1,206	1,160
Leisure time activities:										
Recreation:										
Number of memberships	4,762	3,968	3,358	2,153	2,653	3,100	3,187	2,767	1,348	1,794
Community development:										
Parking fees collected due to Economic development dept.	\$ 995,999	\$ 976,591	\$ 975,500	\$ 968,732	\$ 965,031	\$ 985,439	\$ 985,758	\$ 987,855	\$ 991,597	\$ 981,453
Public works:										
Refuse disposal per year (tons)	10,901	10,930	10,870	7,129	7,423	9,483	9,734	8,840	10,502	9,083
Refuse disposal costs per year	\$ 386,998	\$ 378,919	\$ 361,016	\$ 272,325	\$ 298,457	\$ 340,659	\$ 357,231	\$ 429,612	\$ 469,575	\$ 459,222
Percentage of waste recycled	2.00%	4.00%	9.00%	10.42%	15.44%	10.00%	12.79%	10.11%	10.38%	
Transportation:										
Snowfall in inches	58.40	69.50	38.90	68.10	64.60	60.00	68.00	68.1	30.7	40.0
Cost of salt purchased	\$ 222,818	\$ 100,124	\$ 127,428	\$ 167,207	\$ 188,632	\$ 213,392	\$ 201,121	\$ 88,532	\$ 197,521	\$ 246,980
Asphalt used in road maintenance (tons)	348	76	272	336	211	283	173	130	203	206
Concrete used in road maintenance (yards)	110	244	179	290	161	202	261	245	90	153
Number of trees removed	78	207	175	213	109	84	183	-	85	98
Number of trees planted	80	8	15	100	-	-	-	-	-	-
Senior citizen driveway plowing participants	1,210	1,140	1,096	1,149	-	-	-	-	-	-

Source: Information was provided from the various departments within the City

City of Brook Park, Ohio

Capital Assets Statistics by Function/Program

Last Ten Years

Table 18

	2010	2011	2012	2013	2014	2015	2016	2017	2018	2019
Function/program:										
General government:										
City Hall square footage	16,880	16,880	16,880	16,880	16,880	16,880	16,880	16,880	5,600	5,600
Other departmental vehicles	12	12	12	12	12	12	12	12	12	12
Security of persons and property:										
Police:										
Stations	1	1	1	1	1	1	1	1	1	1
Square footage of Police (and Fire) building	16,072	16,072	16,072	16,072	16,072	16,072	16,072	16,072	16,072	16,072
Number of vehicles	33	33	41	34	30	30	33	30	35	35
Number of street lights	2,565	2,565	2,565	2,565	2,565	2,565	2,565	2,565	2,565	2,565
Number of traffic lights	44	44	44	44	44	44	44	44	44	44
Fire:										
Stations	3	2	2	2	2	2	2	2	2	2
Square footage of station	16,072	16,072	16,072	16,072	16,072	16,072	16,072	16,072	16,072	16,072
Square footage of station - Ruple	3,807	3,807	3,807	3,807	3,807	3,807	3,807	3,807	3,807	3,807
Number of Vehicles	15	14	14	13	14	14	14	14	14	14
Leisure time activities:										
Recreation:										
Number of Parks	7	7	7	7	7	7	7	7	7	7
Number of Pools	2	2	2	2	2	2	2	2	2	2
Number of Diving Tanks	1	1	1	1	1	1	1	1	1	1
Square footage of Recreation Center	105,300	105,300	105,300	105,300	105,300	105,300	105,300	105,300	105,300	105,300
Public works:										
Streets (miles)	46	46	46	46	46	46	46	46	46	46
Service vehicles	74	74	74	74	74	74	75	75	77	77

Source: Information is provided from the City's capital asset records

This page is intentionally left blank.

OHIO AUDITOR OF STATE KEITH FABER



CITY OF BROOK PARK

CUYAHOGA COUNTY

CLERK'S CERTIFICATION

This is a true and correct copy of the report which is required to be filed in the Office of the Auditor of State pursuant to Section 117.26, Revised Code, and which is filed in Columbus, Ohio.

Susan Babbitt

CLERK OF THE BUREAU

**CERTIFIED
JULY 28, 2020**